



# PUMA VTS series

## PUMA VTS1214 / 1620

Large Vertical Turning Center with RAM Head Spindle



# PUMA VTS series

## PUMA VTS1214 / 1620

With its large capacity and heavy duty machining capability,  
The PUMA VTS series provides excellent productivity for large workpieces



# Features

## 1 Robust Structure

The PUMA VTS series provides optimum durability by including box guideway construction to all linear axes. The large diameter cross taper roller bearing used in the spindle construction provides high rigidity and accuracy for heavy duty machining applications

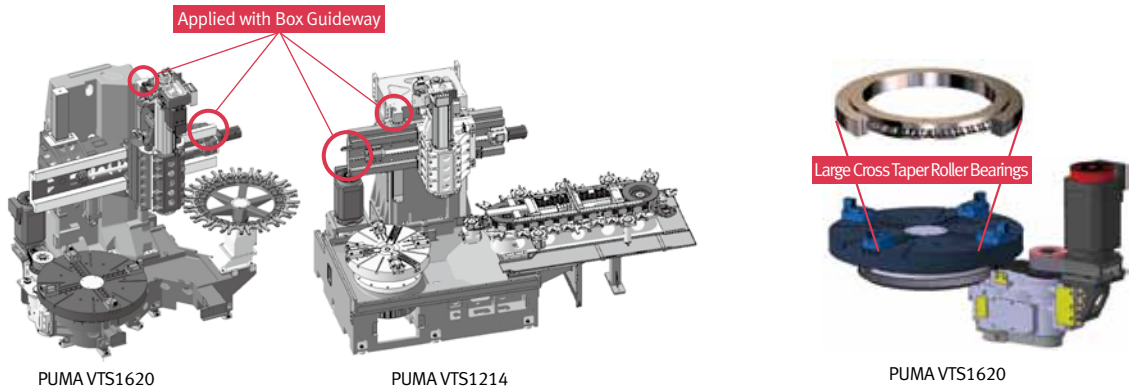

## 2 Highest Cutting Capacity among Competitors

Provides maximum workpiece size capacity

Max. Turning diameter

PUMA VTS1620  
**Ø 2000 mm**  
(78.7 inch)

PUMA VTS1214  
**Ø 1350 mm**  
(53.1 inch)

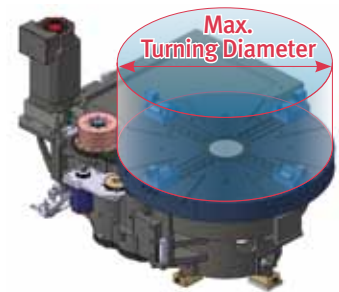

# Robust Mechanical Construction

## PUMA VTS1620 series

The PUMA VTS1620M series provides extended durability and stable accuracy by implementing a large diameter cross roller bearing for the spindle and box guideways for the linear axes.

PUMA VTS1620 series

## Machine Construction

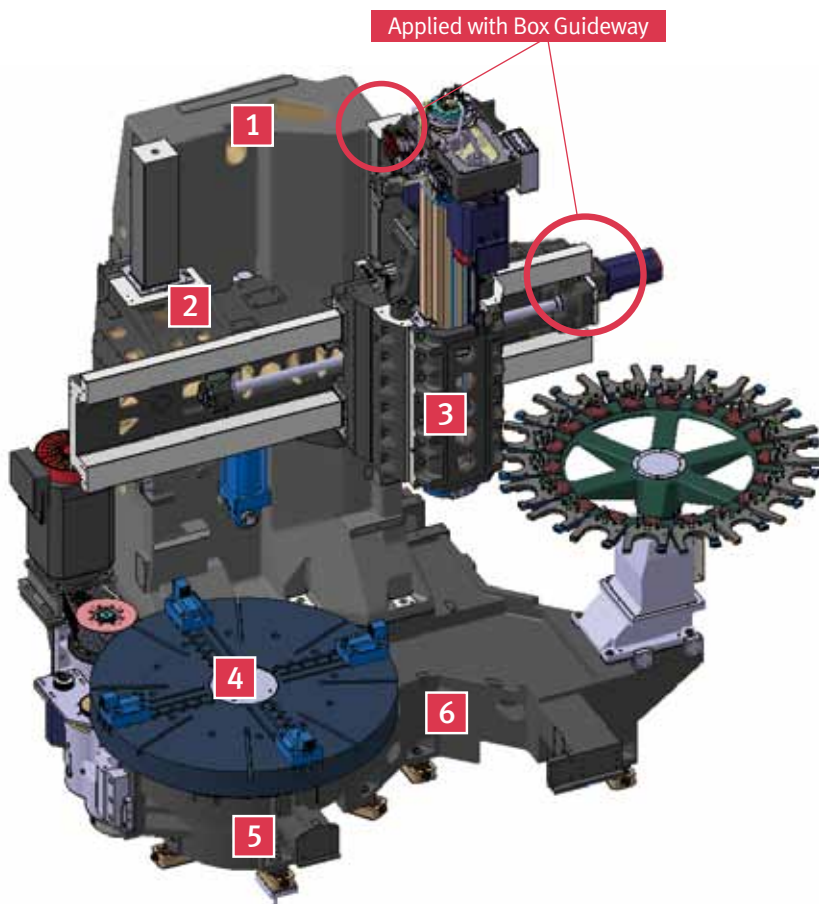

Model : PUMA VTS1620 Core Machine

1

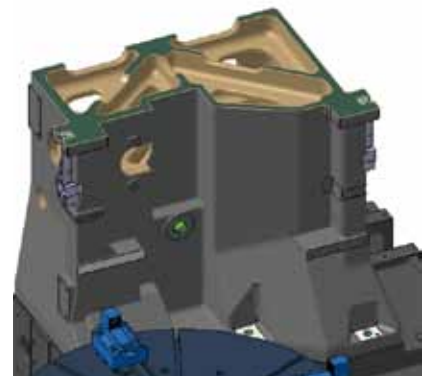

A highly rigid X-type cast Meehanite column structure reduces deflection and ensures optimum cutting performance.

2

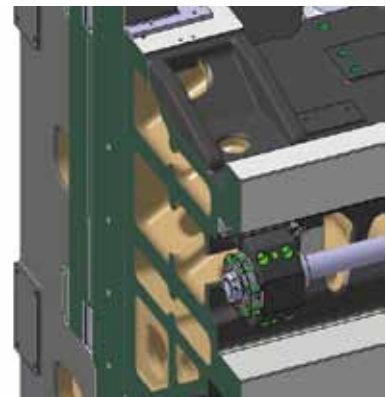

Deflection is avoided by the high rigidity crossrail and ram carriage construction.



3



Large square cross-section  
**308 × 250 mm**  
 (12.1 × 9.8 inch)

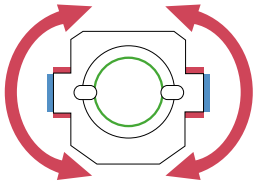

Wide ram guide for high torque

Ram deformation minimized by enlarged guideway design enabling heavy duty cutting.

5

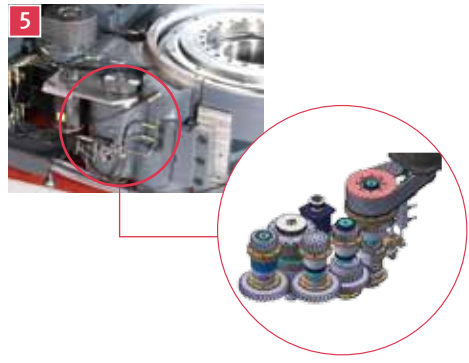

Applied with powerful helical gears to guarantee a long life. The VTS1620M is applied with a zero backlash system to realize accurate C axis control.

4

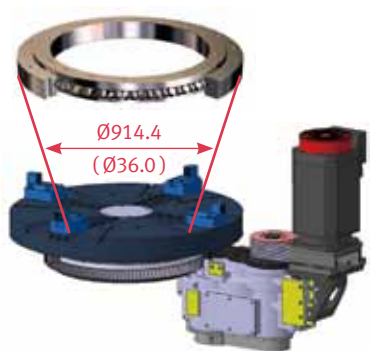

Designed with large diameter cross taper roller bearing featuring high rigidity in both radial and axial directions. The gears are capable of transmitting high cutting forces.

6



Designed in a base structure that provides a stable cutting performance to the table and carriage, using an X rib structure Meehanite casting.

Max. Table motor	Max. Table torque	Max. Table speed
<b>45</b> {60} kW	<b>19875</b> {24380} N·m	<b>250</b> r/min
(60.3 {80.5} Hp)	(14667.8 {17992.4} ft·lb)	{ } : Option

# Large Workpiece Capacity and Processing Capability

## Crossrail Fixed Positions

The 4 position step block is provided to fix the W axis position of the crossrail, and in combination with a positioning pin, maintains a high level of positioning control.

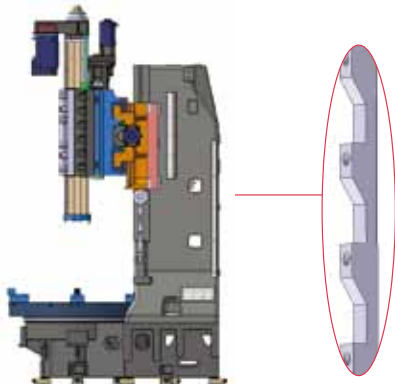

Crossrail fixed positions

**200 mm × 4 steps = 800 mm**  
 (7.9 inch) (31.5 inch)  
 (actuated by hydraulic cylinder)

## Axis Travel

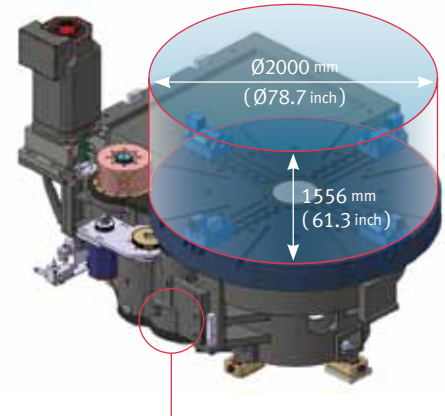

The built in 2-step gearbox provides a stable high torque drive

Max. Turning diameter	<b>Ø2000 mm</b> (78.7 inch)	Z-axis	<b>960 mm</b> (37.8 inch)
Max. Turning height	<b>1556 mm</b> (61.3 inch)	W-axis	<b>800 mm</b> (31.5 inch)
Max. Allowable load	<b>10000 kg</b> (22045.9 lb)	X-axis	<b>1727 mm</b> (68.0 inch)

## ATC Magazine



Driving system	<b>Servo motor</b>
No. of tool stations	<b>18 { 24 } stations</b>
Max. Tool length in Z-axis	<b>450 mm (17.7 inch)</b> (Static tool)
	<b>350 mm (13.8 inch)</b> (BT50 / DIN 50 rotating tool)
Max. Tool weight	<b>50 Kg (110.2 lb) / tool</b> { } : Option

## C-axis Table

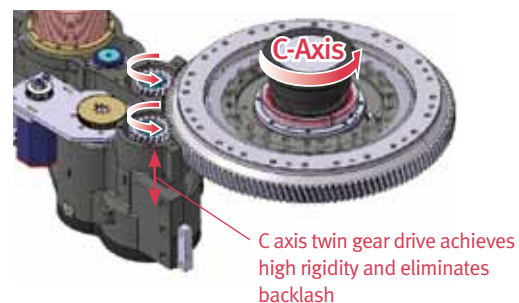

C axis twin gear drive achieves high rigidity and eliminates backlash

### C-Axis Servo Motor VTS 1620 (M)

Max. Power and torque	<b>4 kW (5.4 Hp)</b> <b>26400 N·m (19483.2 ft·lb)</b>
C-axis feedrate	<b>900 deg/min</b> (travel 360°, 0.001° control)

Servo controlled c-axis table enables milling, drilling and tapping with excellent rotational accuracy and user satisfaction.

## Table Motor Power - Torque



Max. Table motor & torque

**45 kW**      **19875 N·m**  
(60.3 Hp)    (14667.8 ft·lb)

Max. Table motor & torque **opt.**

**60 kW**      **24380 N·m**  
(80.5 Hp)    (17992.4 ft·lb)

### Low Gear

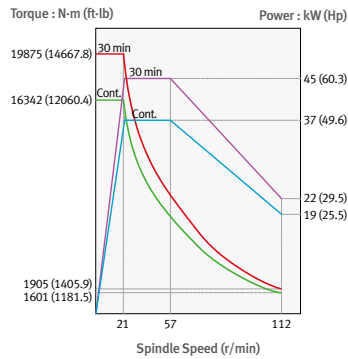

### High Gear

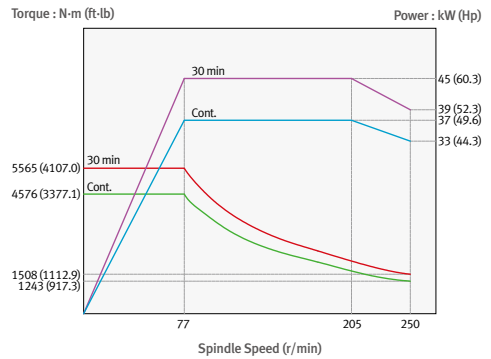

### Low Gear **opt.**

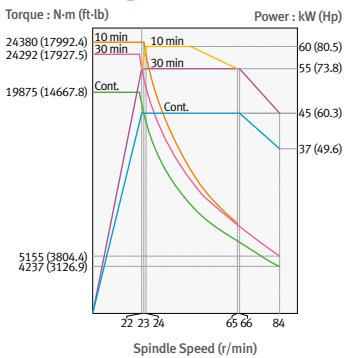

### High Gear **opt.**

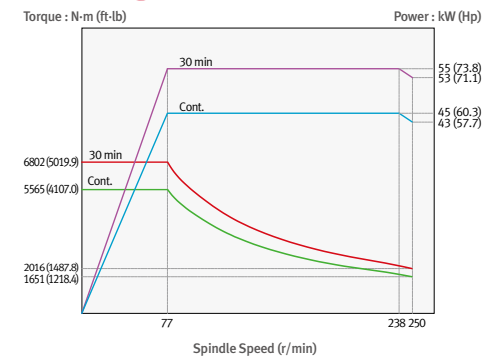

## Ram Rotary Spindle

(common for PUMA VTS1214M / VTS1620M)

Max. Rotary tool power

**18.5 kW**      **15 kW **opt.****  
(24.8 Hp)      (20.1 Hp)

Max. Rotary tool torque

**262 N·m**      **687 N·m **opt.****  
(193.4 ft·lb)    (507.0 ft·lb)

Max. Rotary tool speed

**3000 r/min**      **2000 r/min **opt.****

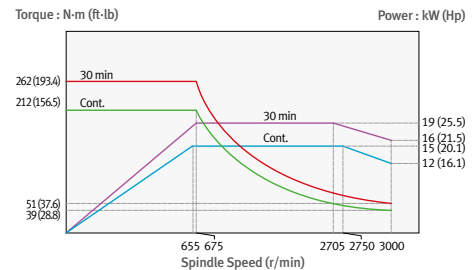

### Low Gear **opt.**

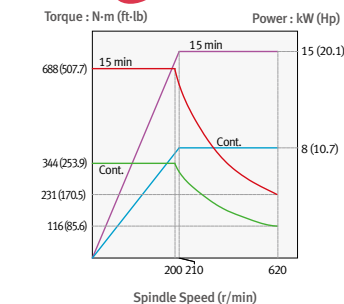

### High Gear **opt.**

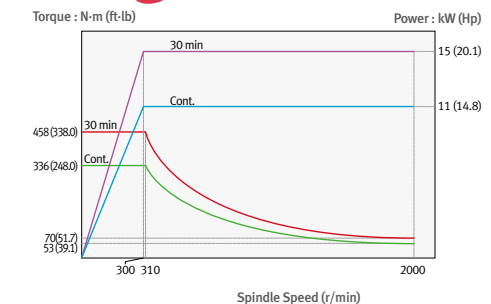

# Robust Mechanical Construction

## PUMA VTS1214 series

The PUMA VTS1214 series has minimized heat and vibration emissions using a separable-type gearbox, and it exhibits a high rigidity in heavy duty cutting using large bearings.

PUMA VTS1214 series

## Machine Construction

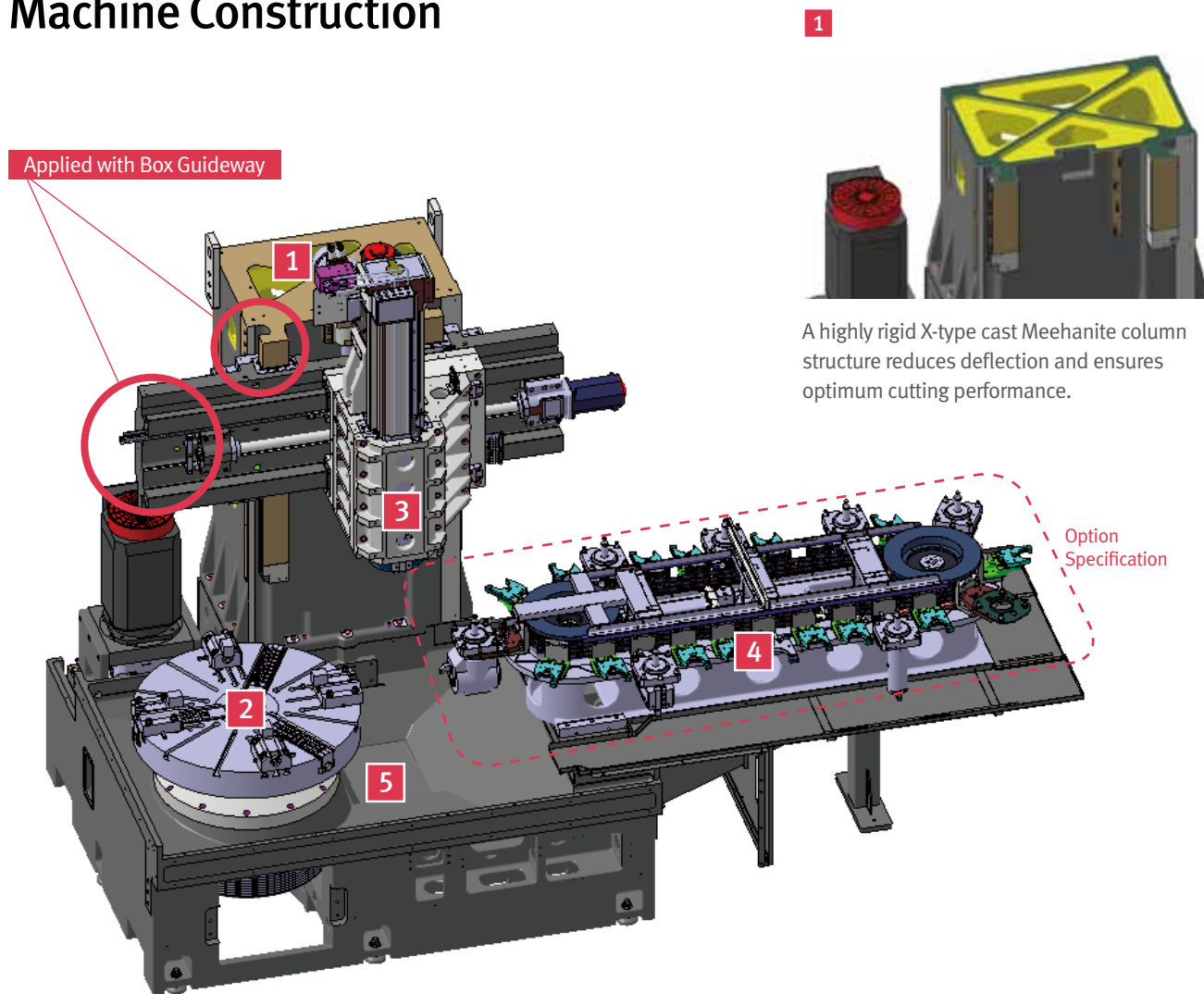

Model : PUMA VTS1214 Core Machine



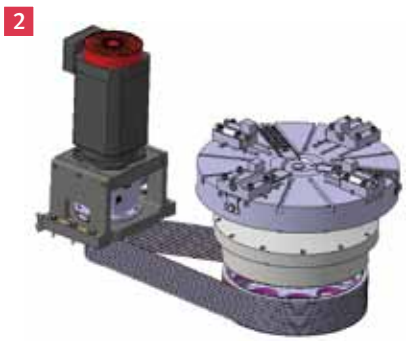

Vibration and heat generation at the spindle are minimized with a belt-driven, detachable gearbox. Cutting capacity and safety are enhanced with large diameter bearings.

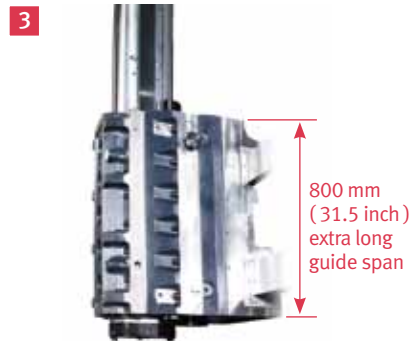

Ram deformation is minimized with an enlarged guideway. A wide ram guide enables heavy duty cutting.

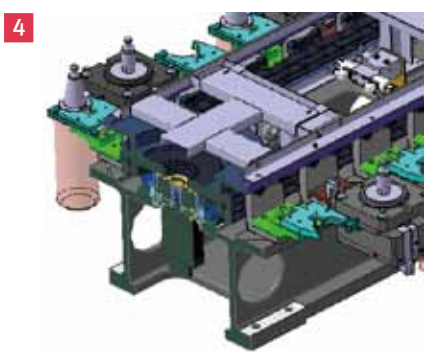
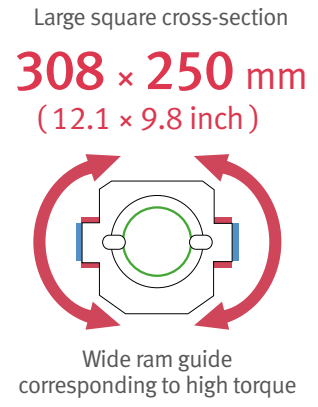

24 tool magazines are reinforced with a rigid rib structure for maximum stability. **opt.**



The column and spindle are rigidly supported using a grid-type, rib structure Meehanite cast. Chips can be easily discharged through the sloped top surface.

# Cutting Capacity

## Crossrail Fixed Positions

The 4 position step block is provided to fix the W axis position of the crossrail, and in combination with a positioning pin, maintains a high level of positioning control.

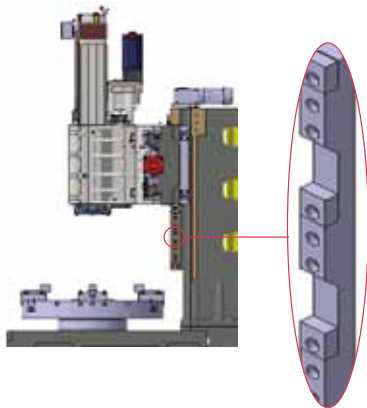

Crossrail fixed positions

**150 mm × 4 steps = 600 mm**  
 (5.9 inch) (23.6 inch)  
 (Geared motor control type)

## Axis Travel

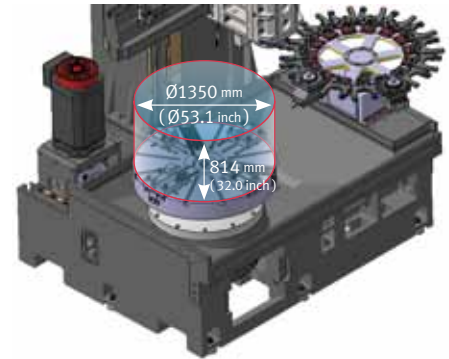

Max Turning diameter **Ø1350 mm (53.1 inch)**  
 Hydraulic chuck **40 " { 50 " }**  
 Swing over bed **1400 mm (55.1 inch)**  
 Max. Workpiece length **814 mm (32.0 inch)**  
 Max. Workpiece weight **4000 kg (8818.4 lb)**  
 (Including chuck) {} : Option

Z-axis	W-axis	X-axis
<b>800 mm</b> (31.5 inch)	<b>600 mm</b> (23.6 inch)	<b>1450 mm</b> (57.1 inch)

## ATC Magazine



Driving system **Servo motor**  
 No. of tool stations **15 { 24 } stations**  
 Max. Tool length **450 mm (17.7 inch) (Static tool)**  
**350 mm (13.8 inch) (BT50 / DIN 50 rotating tool)**  
 Max. Tool weight **50 Kg (110.2 lb) / tool** {} : Option

## Table Motor Power - Torque

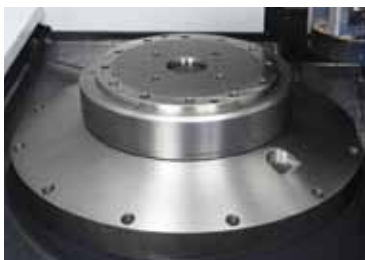

Max. Table Motor & Torque

**60 kW (80.5 Hp)**  
**6412 N·m (4732.1 ft·lb)**

### Low Gear

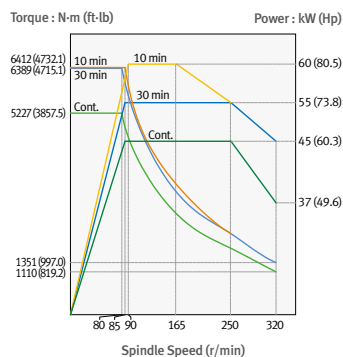

### High Gear

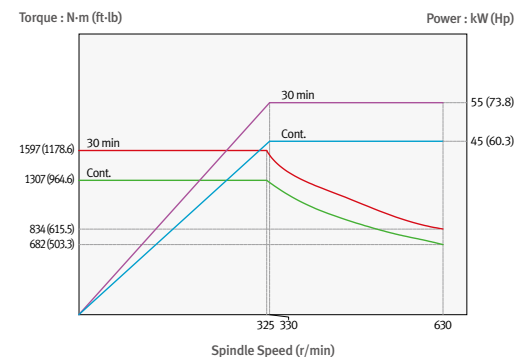

# Optional Equipment and Chip Disposal

## Optional Equipment



Auto door cylinder

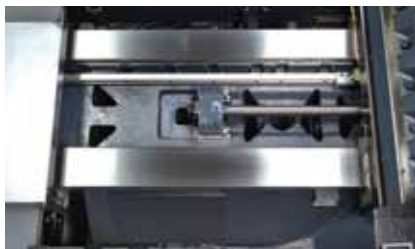

Linear scale



Auto tool setter



Oil mist collector (except PUMA VTS1620)



Oil skimmer



Automatic pallet changer

## Easy Chip Discharge Design

Chips falling off to the left and right are collected in a chip pan and removed by a chip conveyor.

PUMA VTS1620

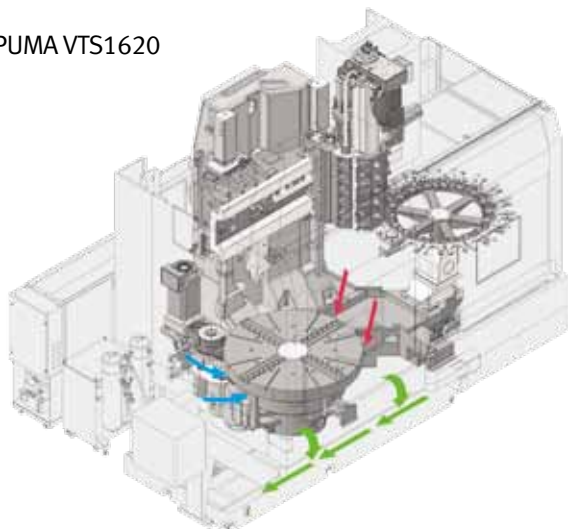

PUMA VTS1214

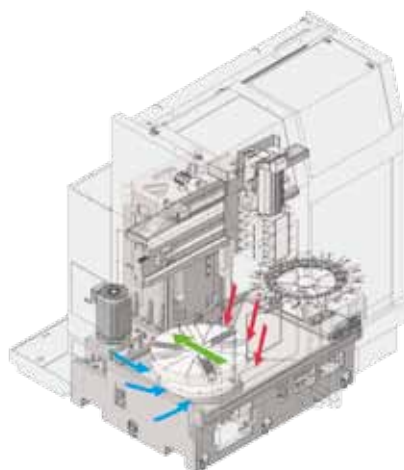

← ATC shower  
← Base shower

### Chip conveyor opt.

Hinge type



Scraper type



### Coolant Chiller opt.

The coolant chiller lowers coolant temperature, helping to cool both the workpiece and tool during the machining operation. When using insoluble cutting oils, a coolant chiller is recommended to cool heated oil and preserve machining precision.

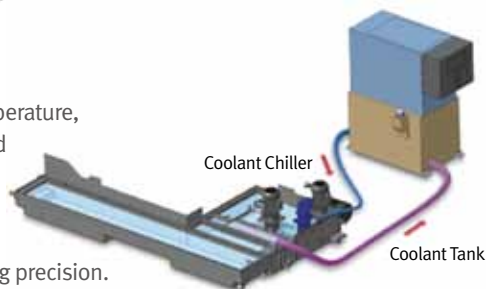

# Tooling System

## 2-axis RAM

Unit: mm (inch)

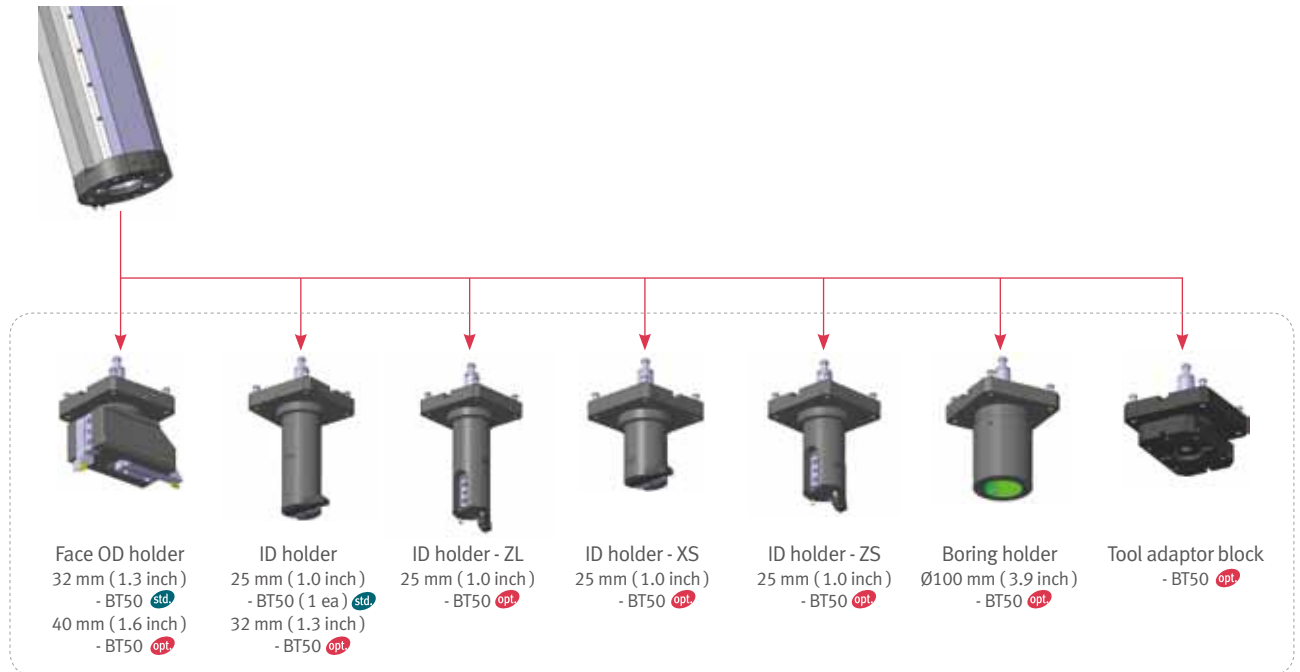

## 3-axis RAM

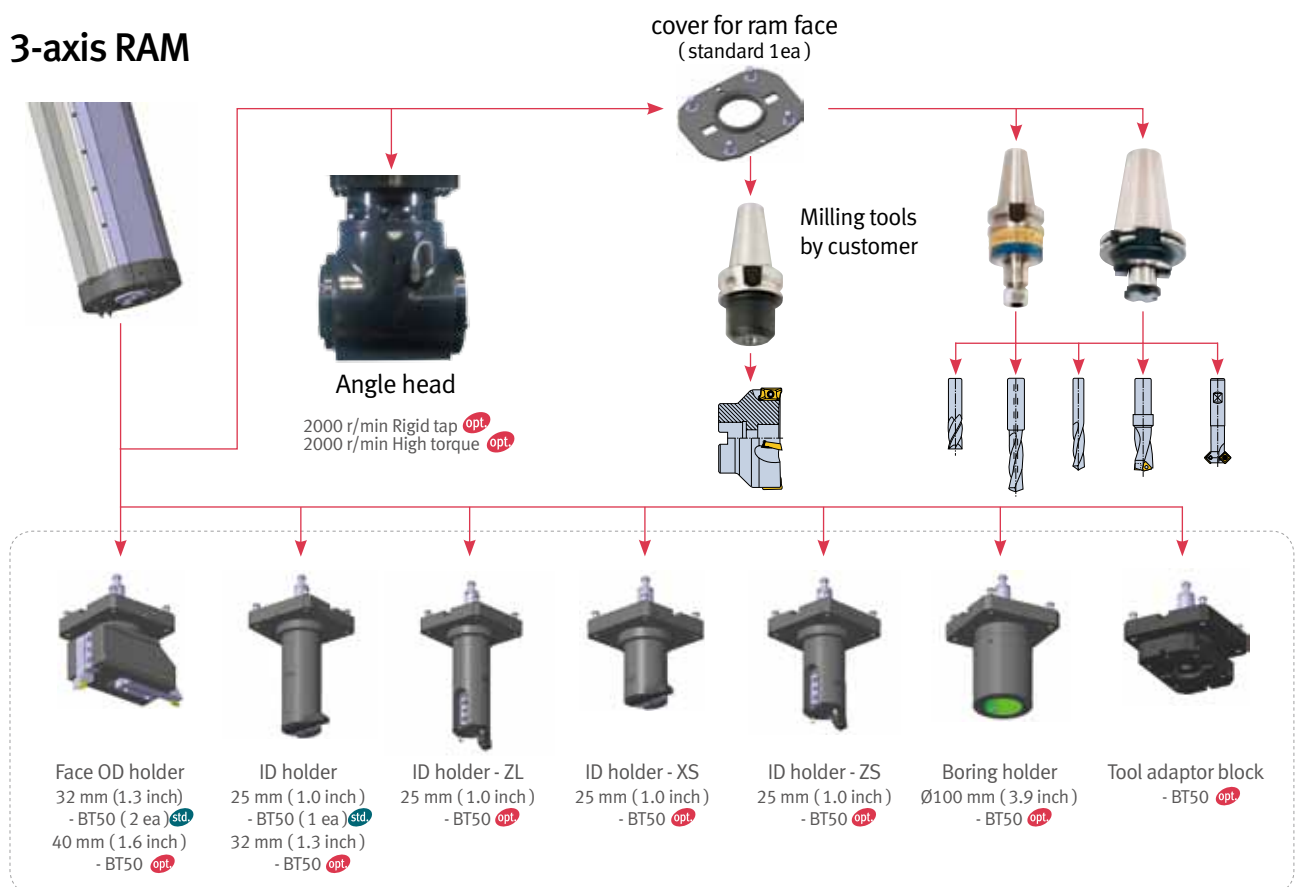

# Tool Holder Dimensions

Unit: mm (inch)

Angle head **opt.**

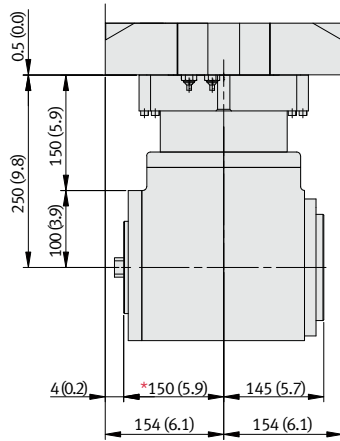

1:1 Rigid tap

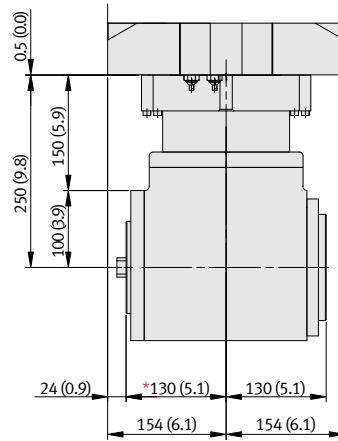

3:2 High torque

\* If the magazine is attached, tools are need to separate.

OD holder

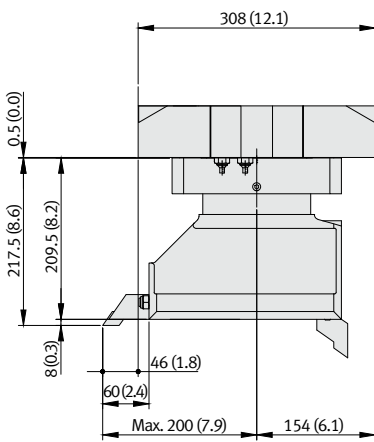

ID holder

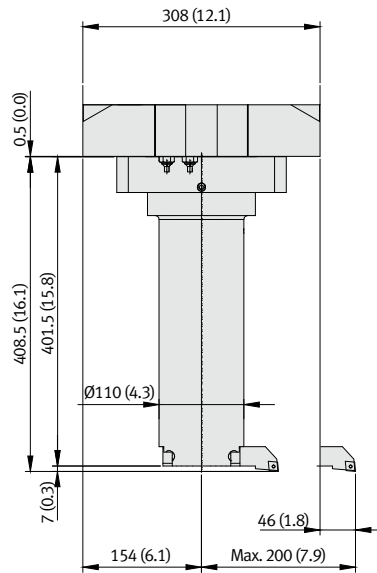

Face holder

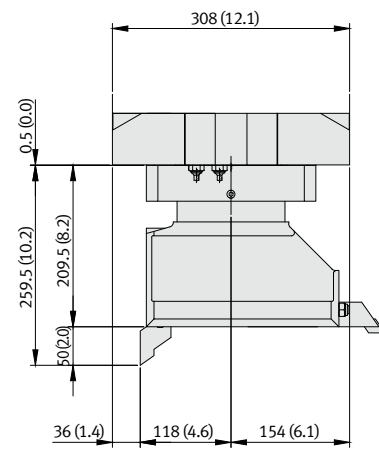

# Easy CNC Set-up and EOP

## Easy Set-up



### Operating console

- 1 Doosan-Fanuc i series
- 2 10.4" color TFT LCD Monitor  
Various alarm messages indicating errors from the machine and controller will be displayed on the 10.4" LCD screen, enhancing the operator's convenience.
- 3 PCMCIA Card
- 4 USB Port  
(only DOOSAN Fanuc i series)
- 5 Swivel-type Operating Console
- 6 Ethernet function ( embedded )

## ATC Guidance

ATC guidance main screen display



Guidance screen for ATC tool change



Tool holder information screen



## Cross Rail Manual Fine Feeding

Fine feeding for the cross rail service and adjustment



Select jog mode for fine feeding of cross rail

JOG mode

# Working Range

## PUMA VTS1620 / VTS1620M

Unit: mm (inch)

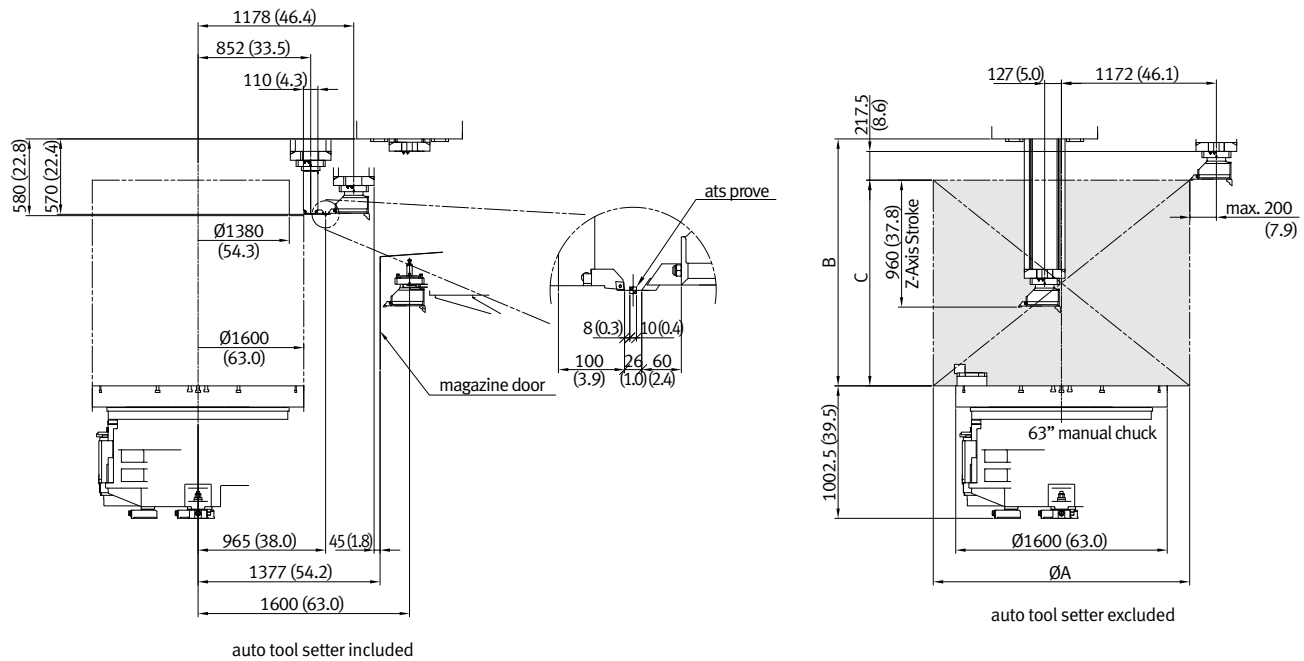

	A	W-Axis 1 Step ; 0		W-Axis 2 Step ; 200		W-Axis 3 Step ; 400		W-Axis 4 Step ; 600		W-Axis 5 Step ; 800	
		B	C	B	C	B	C	B	C	B	C
Face Tool Holder	2000 (78.7)		716 (28.2)		916 (36.1)		1116 (43.9)		1316 (51.8)		1516 (59.7)
OD Tool Holder	1940 (76.4)	968 (38.1)	756 (29.8)	1168 (46.0)	956 (37.6)	1468 (57.8)	1156 (45.5)	1668 (65.7)	1356 (53.4)	1868 (73.5)	1556 (61.3)
X-Long ID Tool Holder	2000 (78.7)		567 (22.3)		767 (30.2)		967 (38.1)		1167 (45.9)		1367 (53.8)

## PUMA VTS1214 / VTS1214M

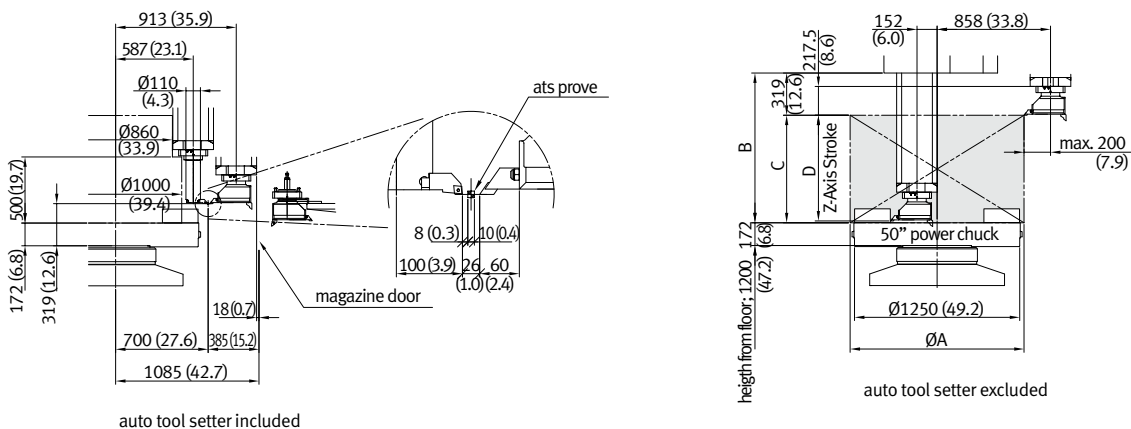

	A	W-Axis 1 Step ; 0 mm			W-Axis 2 Step ; 150 mm (5.9 inch)			W-Axis 3 Step ; 300 mm (11.8 inch)			W-Axis 4 Step ; 450 mm (17.7 inch)			W-Axis 5 Step ; 600 mm (23.6 inch)			
		B	C	D	B	C	D	B	C	D	B	C	D	B	C	D	
Face Tool Holder	1350 (53.1)		172 (6.8)		322 (12.7)		472 (18.6)		622 (24.5)		772 (30.4)		922 (36.3)		1072 (42.2)		1222 (48.1)
OD Tool Holder	1316 (51.8)	533 (21.0)	214 (8.4)	350 (13.8)	683 (26.9)	364 (14.3)	500 (19.7)	833 (32.8)	514 (20.2)	650 (25.6)	983 (38.7)	664 (26.1)	800 (31.5)	1133 (44.6)	814 (32.0)	950 (37.4)	1100 (43.3)
X-Long ID Tool Holder	1350 (53.1)		23 (0.9)		173 (6.8)		323 (12.7)		473 (18.6)		623 (24.5)		773 (30.4)		923 (36.3)		1073 (42.2)

# External Dimension

## PUMA VTS1620 / VTS1620M

Unit: mm (inch)

Top View

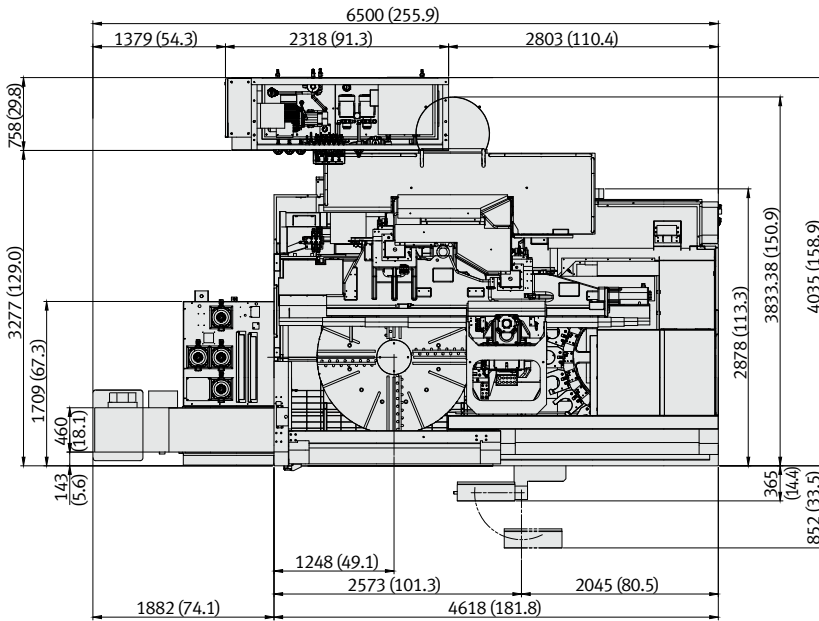

Front View

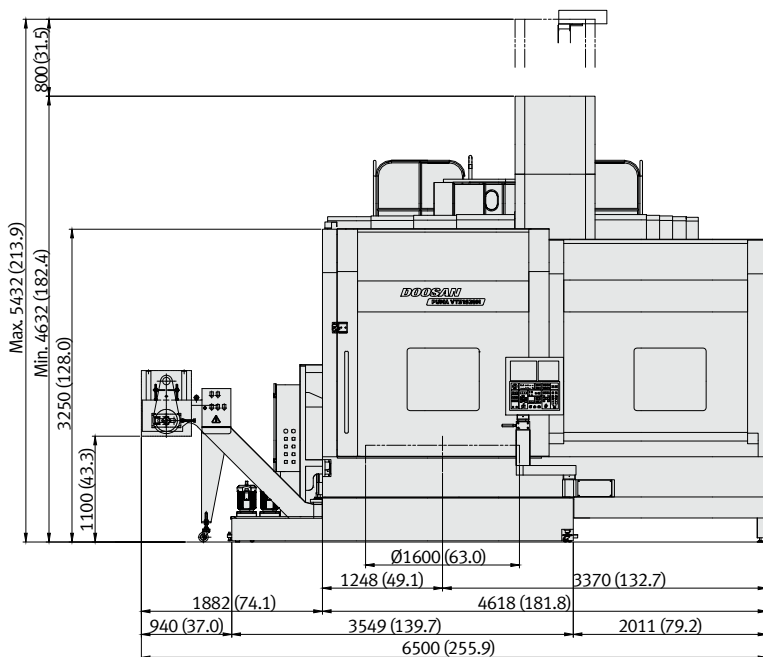

Side View

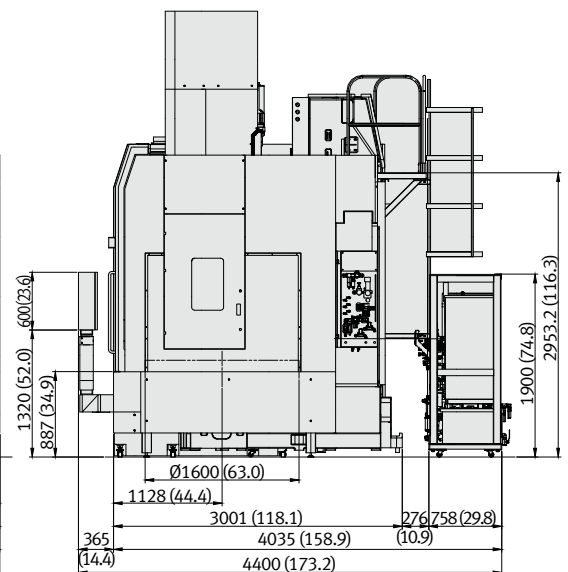



# External Dimension

## PUMA VTS1214 / VTS1214M

Unit: mm (inch)

Top View

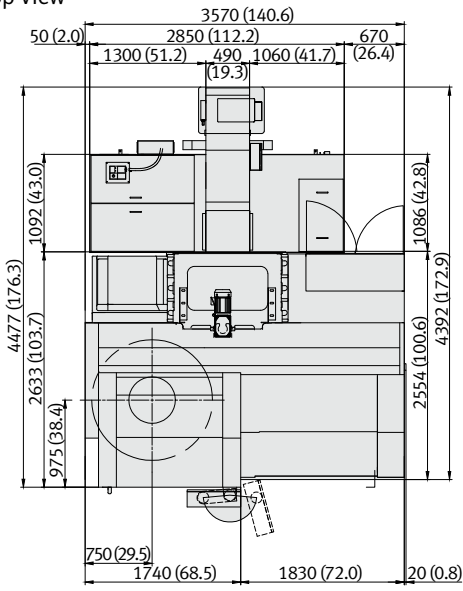

Front View

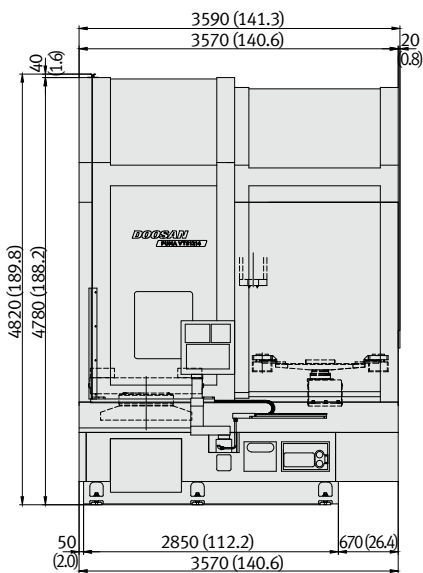

Side View

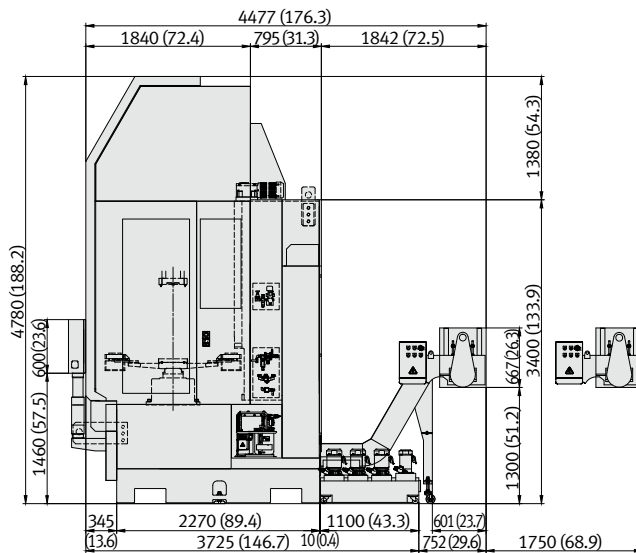

# Machine Specifications

Features		Unit	PUMA VTS1620	PUMA VTS1620M	PUMA VTS1214	PUMA VTS1214M*	
Capacity	Swing over bed	mm (inch)	2000 (78.7)		1400 (55.1)		
	Swing over cross rail	mm (inch)	600 (23.6)		750 (29.5)		
	Max. Turning diameter	mm (inch)	2000 (78.7)		1350 (53.1)		
	Max. Turning height	mm (inch)	1556 (61.3)		814 (32.0)		
	Max. Turning weight	kg (lb)	10000 (22045.9)		4000 (8818.4)		
Travels	Travel distance	X-axis (To left from table center)	mm (inch)	127 (5.0)		152 (6.0)	
		(To right from table center)	mm (inch)	1600 (63.0)		1298 (51.1)	
	Z-axis	mm (inch)	960 (37.8)		800 (31.5)		
	C-axis	deg	-	360		-	360
	W-axis	mm (inch)	800 (31.5)		600 (23.6)		
Feedrates	Rapid	X-axis	m/min	12		12	
	Traverse	Z-axis	m/min	12		12	
	Rate	C-axis	deg/min	-	900		-
Ram	Ram size	mm (inch)	308 × 250 (12.1 × 9.8)		308 × 250 (12.1 × 9.8)		
	Min. through hole inside diameter	mm (inch)	320 (12.6)		320 (12.6)		
Table	Max. Spindle speed	r/min	250		630		
	Table size		1600 (63")		1000 (40")		
	Spindle bearing diameter	mm (inch)	685.8 (27.0)		240 (9.4)		
Rotary Tool	Max. rotary tool spindle torque	ea	-	262 { 687 }		-	262 { 687 }
	Max. roatry tool spindle speed	mm (inch)	-	3000 { 2000 } (118.1 { 78.7 })		-	3000 { 2000 } (118.1 { 78.7 })
	Rotary tool bearing diameter	mm (inch)	-	100 (3.9)		-	100 (3.9)
Tool magazine	Tool storage capa.	stations	18 { 24 }		15 { 24 }		
	Tool size	Face OD	32 × 32		32 × 32		
ID		25 × 25		25 × 25			
Motors	Table motor power	kW (Hp)	45 (60.3) / 37.5 (50.3) (30min/cont.) { 60 (80.5) / 45 (60.3) (10min/cont.) }		60 (80.5) / 55 (73.8) / 45 (60.3) (10min/30min/cont.)		
	Rotary tool motor power	kW (Hp)	-	18.5 (24.8) / 15 (20.1) (30min/cont.) { 15 (20.1) / 11 (14.8) (30min/cont.) }		-	18.5 (24.8) / 15 (20.1) (30min/cont.) { 15 (20.1) / 11 (14.8) (30min/cont.) }
Power source	Electric power supply ( rated capacity )	kVA	90	110	90	110	
Machine Dimensions	Height	mm (inch)	5639 (222.0)		4820 (189.8)		
	Width	mm (inch)	5200 × 3451 (204.7 × 135.9)		3590 × 3725 (141.3 × 146.7)		
	Weight	kg (lb)	30000 (66137.7)	31000 (68342.3)	25500 (56217.0)	26000 (57319.3)	
NC CONTROL			DOOSAN Fanuc i series / Fanuc 32i				

\* For machining accuracy of X / C axes contouring, please contact Doosan.  
{ } : Option

## Standard Feature

- 3 jaws hydraulic chuck (VTS1214/M)
- 4 jaws manual chuck (VTS1620/M)
- ATC shower coolant
- Bed shower coolant
- Column ladder and rail (VTS1620/M)
- Crossrail positioning unit
- Hydraulic unit
- Leveling bolts and plates
- Lubricant supplier
- Machine installation parts
- M code program (Drive vertical crossrail)
- Ram air blast
- Ram shower coolant
- Splash guard
- Standard tool holder
- Table cooling system (VTS1620/M)
- Tool clamp air seating checker

## Optional Feature

- 50" hydraulic chuck (VTS1214/M)
- 50" combination chuck (VTS1214/M)
- 63" combination chuck (VTS1620)
- 70 bar coolant
- Air conditioner
- Automatic front door
- Auto tool setter
- Chip bucket, chip conveyor
- Coolant gun
- Linear scale (X, Z-axis)
- Line filter for coolant
- Mist collector (VTS1214/M)
- Oil Skimmer (belt type)
- Parts probe
- Signal tower
- Special chuck

• The specifications and information above-mentioned may be changed without prior notice.  
• For more details, please contact Doosan

# NC Unit Specifications

## DOOSAN Fanuc i series

### Standard Specifications

#### AXES CONTROL

- Controlled axes X, Z, C (X, Z, C, E - VT)
- Simultaneously controllable axes 3 axes
- Axis control by PMC
- Backlash compensation 0 ~ ± 9999 pulses
- Backlash compensation for each rapid traverse and cutting feed
- Chamfering on / off
- Cs contouring control
- HRV2 control
- Inch / Metric conversion
- Increment system 1/10

- Interlock All axes / each axis
- Least input command 0.001 / 0.0001 mm/inch
- Machine lock All axes / each axis
- Overtravel
- Position switch
- Stored stroke check 1
- Stored stroke check 2, 3

#### OPERATION

- Automatic operation ( memory )
- Buffer register
- DNC operation (Reader / puncher interface is required)
- Handle incremental feed X1, X10, X100
- JOG feed
- Manual handle feed 1 unit
- Reference position setting without dog
- Wrong operation prevention

#### INTERPOLATION FUNCTIONS

- 1st. reference position return Manual, G28
- 2nd. reference position return G30
- 3rd / 4th. reference position return G30
- Circular interpolation G02
- Continuous threading
- Dwell ( per sec ) G04
- Linear interpolation G01

- Polar coordinate interpolation
- Positioning G00
- Reference position return check G27
- Thread cutting / Synchronous cutting

#### FEED FUNCTION

- Automatic acceleration / deceleration
- Cutting feedrate clamp
- Feedrate override ( 10% unit ) 0 - 200 %
- Jog feed override ( 10% unit ) 0 - 2000 mm/min
- Override cancel
- Rapid traverse override F0,25, 100 %
- Tangential speed constant control

#### AUXILIARY / SPINDLE SPEED FUNCTION

- Constant surface speed control
- High speed M / S / T interface
- Spindle orientation

#### PROGRAM INPUT

- Absolute / incremental programming
- Addition of custom macro common variables
- Automatic coordinate system setting
- Canned cycle for drilling / Turning
- Circular interpolation by R programming
- Coordinate system setting G50
- Custom macro

- Decimal point programming / Diameter/radius programming ( X axis )
- Direct drawing dimension programming
- Direct of coordinate system shift
- G code system A / B / C
- Input unit 10 time multiply
- Maximum program dimension ±9 digit
- Multiple repetitive canned cycle G70 - G76
- Multiple repetitive canned cycle II
- Optional block skip 1 piece
- Optional block skip ( Soft operator's panel ) 9 pieces

- Plane selection G17, G18, G19
- Pocket calculator type decimal point programming

- Program number O4 digit
- Program stop / end (M00, M01 / M02, M30)
- Programmable data input G10
- SUB program call 4 folds nested
- Tape code : ISO / EIA auto recognition EIA RS422 / ISO840
- Tape format for FANUC Series10/11
- Work coordinate system G52 - G59

#### TOOL FUNCTION / TOOL COMPENSATION

- Automatic tool offset
- Direct input of offset value measured B
- Extended tool life management
- T - code function T2 + 2 digits
- Tool geometry / wear compensation
- Tool life management
- Tool nose radius compensation
- Tool offset G43, G44, G49
- Tool offset pairs 64 pairs

#### EDITING OPERATION

- Extended part program editing
- Number of registered programs 400 ea
- Part program storage length 1280 (512KB) m
- Program protect

#### SETTING AND DISPLAY

- Actual cutting feedrate display
- Alarm history display
- Directory display and punch for each group
- Display of spindle speed and T code at all screens
- Multi-language display
- Operating monitor screen
- Parameter setting and display
- Program name display 31 characters
- Run hours / parts count display
- Self-diagnosis function
- Spindle setting screen
- Soft operator's panel
- Tool path graphic display

#### OTHERS

- Cycle start and lamp

- Display unit 10.4" Color TFT LCD (except Lynx220M/300M) 8.4" Color LCD : Lynx220M/300M
- Feed hold and lamp
- NC and servo ready
- PCMCIA port in the front of LCD display unit
- PMC system OiD-PMC
- Reset / rewind

#### OPERATION GUIDANCE FUNCTION

- eZ Guide i Only 10.4 Color LCD
- Manual Guide Oi Only 8.4 Color LCD

#### INTERFACE FUNCTION

- Ethernet function Embedded ethernet

### Optional Specifications

#### AXIS CONTROL

- Controlled axes expansion (total) Max. 4 axes
- Simultaneous controlled axes expansion (total) Max. 4 axes

#### OTHERS

- 10.4" Color TFT LCD (Only Lynx220M/300M)
- Advanced preview control
- Dynamic graphic display Only Lynx-series
- Fast ethernet / Data server
- Helical interpolation
- High speed skip function
- Manual handle interruption
- Manual handle feed 2 units
- Number of tool offset 99 pairs

#### ROBOT INTERFACE

- Robot interface with PMC I/O module (Hardware between PMC I/O modules)
- Robot interface with PROFIBUS-DP

#### TOOL FUNCTION / TOOL COMPENSATION

- Tool Load Monitoring system

## FANUC 32i

### Standard Specifications

#### AXES CONTROL

- Controlled axes X, Z
- Simultaneously controlled axes 2 axes
- Axis control by PMC
- Backlash compensation 0 ~ ± 9999 pulses
- Backlash compensation for each rapid traverse and cutting feed
- Controlled path 1 path
- HRV2 control
- Inch / Metric conversion
- Interlock All axes / each axis
- Least input command 0.001 / 0.0001 mm/inch
- Mirror image
- Servo off
- Stored stroke check 1
- Torque control
- Unexpected disturbance torque detection function

- Interlock All axes / each axis
- Least input command 0.001 / 0.0001 mm/inch
- Mirror image
- Servo off
- Stored stroke check 1
- Torque control
- Unexpected disturbance torque detection function

#### OPERATION

- Automatic operation ( memory )
- Buffer register
- DNC Operation with Memory card
- Handle incremental feed X1, X10, X100
- Program restart

#### INTERPOLATION FUNCTIONS

- 1st. Reference position return Manual, G28
- 2nd. reference position return G30
- Circular interpolation G02
- Continuous threading
- Dwell ( per sec ) G04
- Linear interpolation G01
- Positioning G00
- Reference position return check G27
- Thread cutting / Synchronous cutting

#### FEED FUNCTION

- Automatic acceleration / deceleration
- Cutting feedrate clamp
- Feed per revolution
- Feedrate override ( 10% unit ) 0 - 200 %
- Jog feed override ( 10% unit ) 0 - 2000 mm/min

- Override cancel
- Rapid traverse override F0, 25, 100 %
- Tangential speed constant control

#### AUXILIARY / SPINDLE SPEED FUNCTION

- Constant surface speed control
- M - code function M3 digits
- Spindle orientation

#### PROGRAM INPUT

- Absolute / incremental programming
- Automatic coordinate system setting
- Canned cycle for drilling / Turning
- Canned cycle
- Circular interpolation by R programming
- Coordinate system setting G50
- Coordinate system shift
- Custom macro

- Decimal point programming / Pocket calculator type decimal point programming
- Diameter/radius programming ( X axis )
- Direct drawing dimension programming
- G code system A
- G code system B / C
- Input unit 10 time multiply
- Macro executor
- Maximum program dimension ±9 digit
- Multiple repetitive canned cycle G70 - G76
- Multiple repetitive canned cycle II
- Optional block skip 9 pieces
- Plane selection G17, G18, G19
- Program file name 32 characters
- Programmable data input G10
- Sequence number N8 digit
- SUB program call 10 folds nested

- Plane selection G17, G18, G19
- Program file name 32 characters
- Programmable data input G10
- Sequence number N8 digit
- SUB program call 10 folds nested

#### TOOL FUNCTION / TOOL COMPENSATION

- Automatic tool offset
- Direct input of offset value measured B
- T - code function T2 + 2 digits
- Tool life management
- Tool nose radius compensation

- Tool offset G43, G44, G49
- Tool offset pairs ±6 digits : 64 pairs
- Tool offset value counter input

#### EDITING OPERATION

- Extended part program editing
- Number of registered programs 500 ea
- Part program editing
- Part program storage length 640 (256 KB) m

#### SETTING AND DISPLAY

- Actual cutting feedrate display
- Alarm history display
- Display of spindle speed and T code at all screens
- Operation history display
- Operating monitor screen
- Parameter setting and display
- Periodic maintenance screen
- Program comment display 31 characters
- Run hours / part count display
- Self-diagnosis function
- Servo waveform display
- Spindle setting screen

#### OTHERS

- Cycle start and lamp
- Display unit 10.4" Color TFT LCD
- Feed hold and lamp
- NC and servo ready
- PMC system 32i-PMC
- Reset / rewind

#### OPERATION GUIDANCE FUNCTION

- eZ Guide i (Conversational Programming Solution)

#### INTERFACE FUNCTION

- Ethernet function Embedded ethernet

### Optional Specifications

#### AXIS CONTROL

- Automatic tool compensation
- Stored stroke 2 and 3
- Stroke limit check before move

#### OPERATION

- Active block cancel
- DNC operation (Reader / puncher interface is required)
- Manual handle interruption
- Manual intervention and return
- Reference position shift

#### INTERPOLATION FUNCTIONS

- 3rd / 4th reference point return
- Circular threading
- Multi step skip

#### PROGRAM INPUT

- Addition of workpiece coordinate system pair 48 pairs
- Additional macro variables #100 ~ #199, #500 ~ #999

- Automatic corner override
- Chamfering on/off
- Interruption type custom macro
- Optional block skip (Soft operator's panel) 9 pieces
- Work coordinate system preset

#### TOOL FUNCTION / TOOL COMPENSATION

- Addition of tool pairs for tool life management 128 pairs
- Tool Load Monitoring system
- Tool offset pairs 99 / 200 / 400 / 999 pairs

#### EDITING OPERATION

- Number of registered programs & Part program storage length 1280M(512KB) 1000 ea, 2560M(1MB) 1000 ea, 5120M(2MB) 1000 ea

#### DATA INPUT/OUTPUT

- DNC1 control
- External data input
- Fast ethernet / Data server
- Remote buffer

#### OTHERS

- High speed skip function
- Manual handle interruption
- Stored pitch error compensation

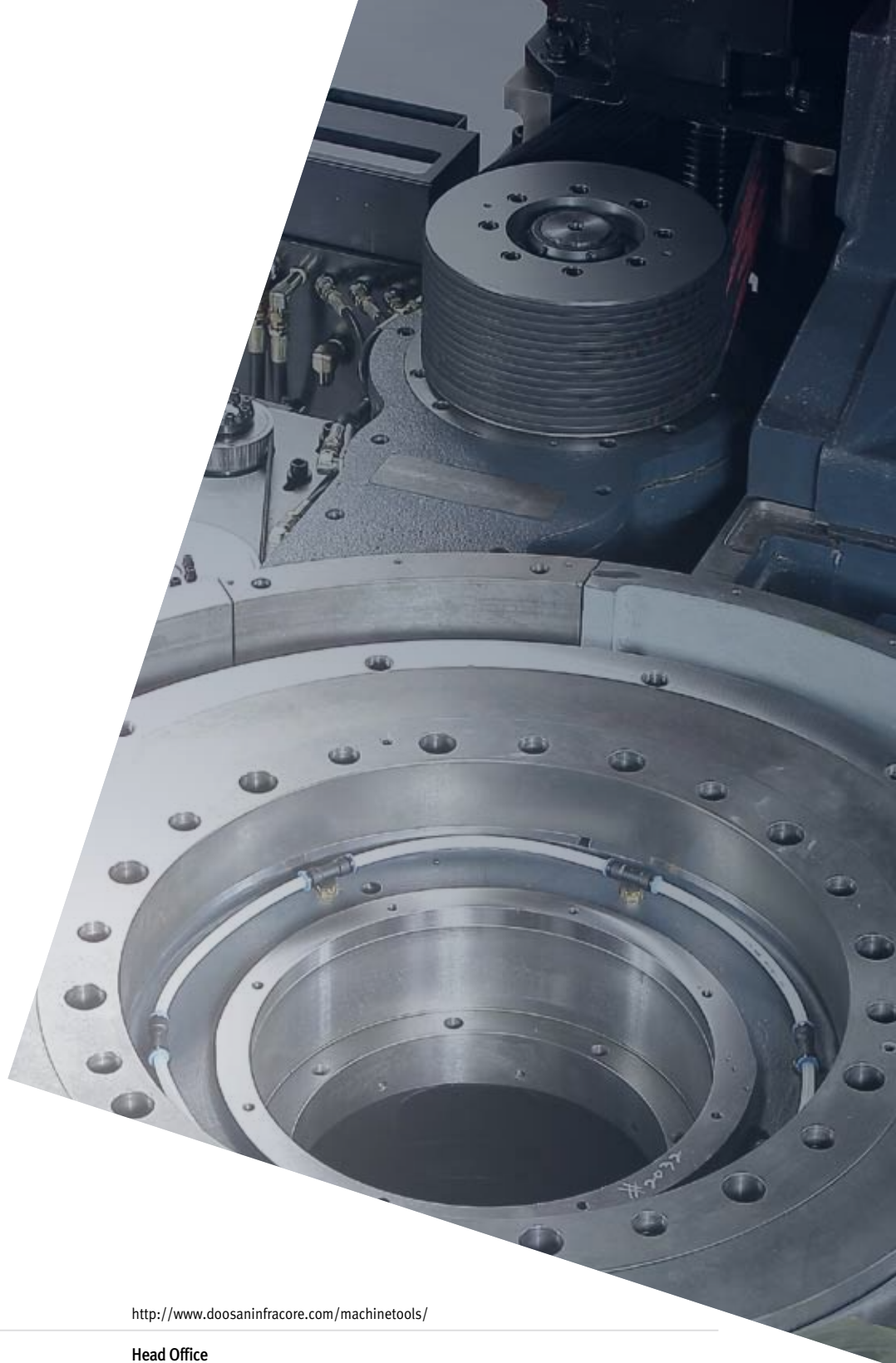

<http://www.doosaninfracore.com/machinetools/>

**Head Office**

Doosan Tower 20th FL., 275, Jangchungdan-Ro(St), Jung-Gu, Seoul  
Tel : +82-2-3398-8693 / 8671 / 8680 Fax : +82-2-3398-8699

**Doosan Infracore America Corp.**

19A Chapin Rd., Pine Brook, NJ 07058, U.S.A.  
Tel : +1-973-618-2500 Fax : +1-973-618-2501

**Doosan Infracore Germany GmbH**

Emdener Strasse 24, D-41540 Dormagen, Germany  
Tel : +49-2133-5067-100 Fax : +49-2133-5067-001

**Doosan Infracore Yantai Co., LTD**

13 Building, 140 Tianlin Road, Xuhui District, Shanghai, China (200233)  
Tel : +86-21-6440-3384 (808, 805) Fax : +86-21-6440-3389

**Doosan Infracore India Pvt., Ltd. Technical Center**

106 / 10-11-12, Amruthalli, Bellary road, Byatarayanapura, Bagalore 560092, India  
Tel : +91-80-4266-0100 / 0122 / 0101

**Doosan International South East Asia Pte Ltd.**

42 Benoi Road, Jurong 629903, Singapore  
Tel : +65-6499-0200 Fax : +65-6861-3459

**Doosan Machine Tools**  
*Optimal Solutions for the Future*

