



Optimal Solutions for the Future

Lynx 300 series



**10-inch
High Productivity
Turning Center**

Lynx 300 series

Lynx 300
Lynx 300M

ver. EN 150827 SU

Basic information

Structure
Main Components

Detailed Information

Standard/Option
Applications
Diagrams
Specifications

Customer Support



Lynx 300 series

Lynx 300 series is a 10 inch high productivity turning center optimized for powerful heavy-duty cutting on the basis of highly stable bed structure, roller type LM guide, high power spindle and servo driven turret.



Contents

02 Product Overview

Basic information

04 Structure

05 Main Components

Detailed Information

06 Standard/Option

07 Applications

09 Diagrams

13 Specifications

15 Customer Support

Customer parts sample



Maintain high performance through high speed and high power spindle

high-precision heavy duty cutting enabled via 3500 r/min, 15kW high-speed, high-power spindles

Shorter machining cycle time through the servo turret indexing motor and the high rigidity roller type LM guide

Non-cutting time is minimized by quick rotation and clamping of servo driven type turret and high speed, high rigidity roller type LM guide for all axes

Improved user convenience with ergonomic operation panel, USB port and operation panel rotation

QWERTY keyboard, easy addition of option button, USB port, user-friendly operational panel rotation provide further enhanced user convenience



Structure

Stable high rigidity bed structure and application of roller type LM guide for all axes realize continued high rigidity and high accuracy of the machine

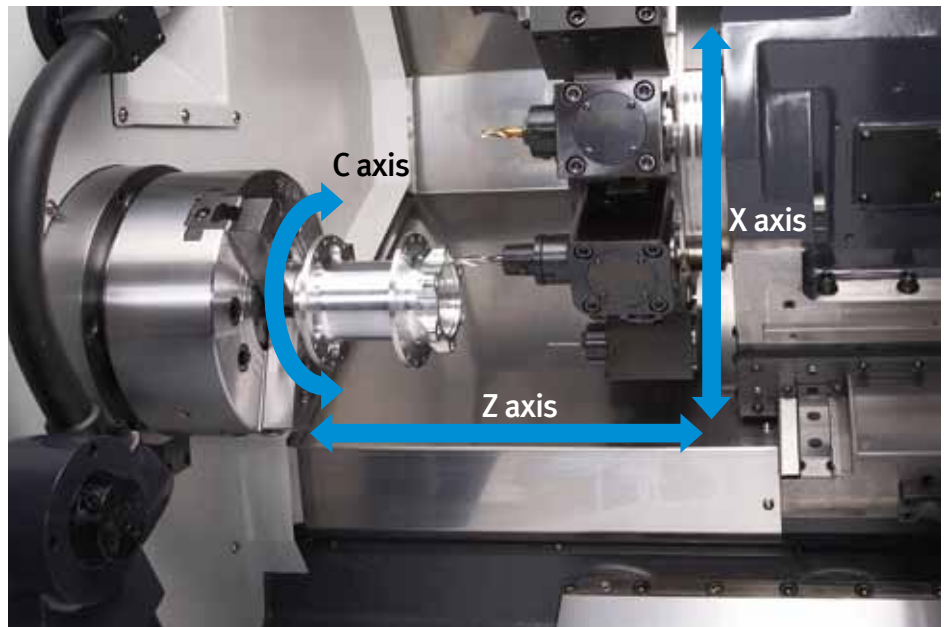

Chuck size

10 inch

Rapid Traverse

X axis : **24** m/min (945 ipm)

Z axis : **30** m/min (1181 ipm)

C axis : **200** r/min (Lynx 300M only)



Machining area

Lynx 300 series offers two models depending on the difference of working range and the presence or absence of milling capacity

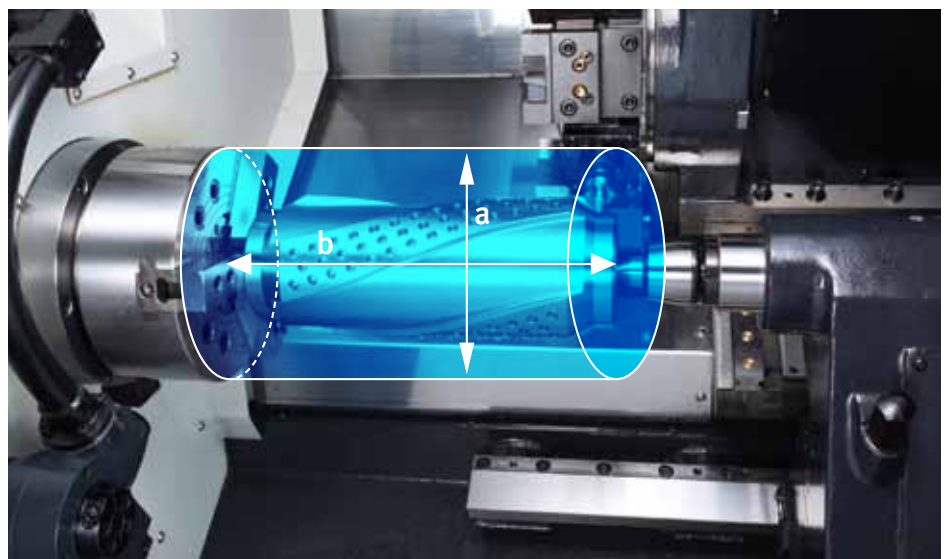

Model	Max. Turning diameter(a)	Max. Turning length(b)	Milling
Lynx 300	450 mm (17.7 inch)	765 mm (30.1 inch)	X
Lynx 300M	370 mm (14.6 inch)	712 mm (28.0 inch)	O

Main components

Each component with the best quality and performance allows the reliable product

Spindle

Special grease type lubrication minimizes the thermal deformation and best-in-class spindle motor with gear box realizes the most powerful cutting capacity.

Max. Spindle speed

3500 r/min

Max. Motor power

15 kW (20 Hp)

18.5 kW (25 Hp) Option

Max. Torque

191 N·m (141 lbf ft)

403 N·m (297 lbf ft) Option

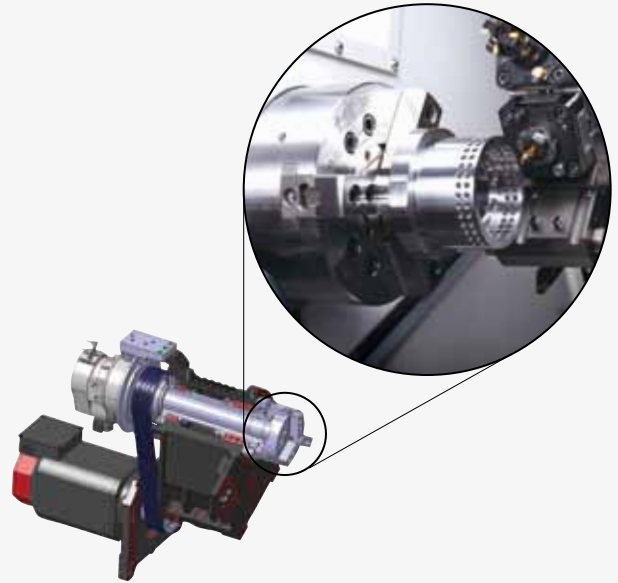

Tailstock

Widely spaced guideways and heavy-duty design of the tailstock body ensure outstanding rigidity and precision

Tailstock Travel

775 mm(30.5 inch)

Quill Dia.	80 mm (3.1 inch)
Quill Travel	120 mm (4.7 inch)
Tail stock Type	Manual (Programmable <small>Option</small>)



Servo driven Turret

High torque servo motor controls rotational acceleration and deceleration of turret and clamping/unclamping operations and its excellent dividing position brings continual high machining accuracy.

No. of tool stations

12 ea



BMT milling turret (Lynx 300M only)

Strongly fixed BMT type milling holder shows more powerful machining performance

Max. Rotary Tool Speed

5000 r/min





Standard / Optional Specifications

Diverse optional devices and features are available to meet specific customer requirements.

● Standard ○ Optional

No.	Description	Features	Lynx 300	Lynx 300M
1	Chuck	10 inch	●	●
2		No chuck	○	○
3	Jaw	Soft jaw	●	●
4		Hard jaw	○	○
5	Chucking Option	DUAL PRESSURE CHUCKING	○	○
6		CHUCK CLAMP CONFIRMATION	○	○
7	Steady rest	Hydraulic (Ø4 ~ Ø165)	○	○
8	V stand	V STAND FOR SHAFT WORKPIECE	○	○
9	Tailstock	Manual	●	●
10		Programmable	○	○
11	Coolant Pump	1.5 bar	●	●
12		Increase Power (4.5/7/10/14.5 bar)	○	○
13	Coolant options	Chuck coolant	○	○
14		Coolant chiller	○	○
15		Oil skimmer	○	○
16		Coolant pressure switch	○	○
17		Coolant level switch	○	○
18		Coolant gun	○	○
19	Chip disposal options	Side type chip conveyor	○	○
20		Rear type chip conveyor	○	○
21		Chip bucket	○	○
22		Air blower	○	○
23		Mist collector	○	○
24	Measuring & automation	Tool setter (manual/automatic)	○	○
25		Part catcher with parts box	○	○
26		Part catcher with parts conveyor	○	○
27		Auto door	○	○
28		Bar feeder interface	○	○
29		Robot interface	○	○
30	Others	Tool load monitoring system	○	○
31		Linear scale	○	○
32		Signal tower	○	○
33		Air gun	○	○
34		Automatic power off	○	○

Applications

Tool setter Option



The tool setter highly reduces tooling setting time through quick tool measurement and tool abrasion detection

Oil skimmer Option



The oil skimmer keeps coolant and lubricant isolated from each other for extending life cycle of coolant.

Coolant system

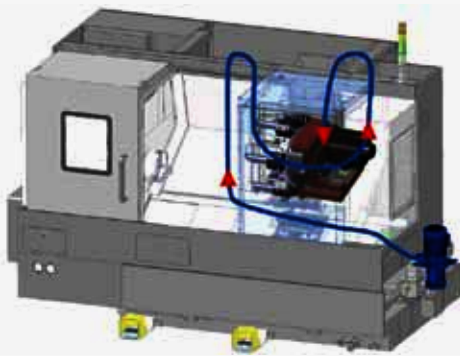

Coolant pump	Pump1	Pump2	Pump3	Pump4	Pump5
Output pressure (bar)	1.5	4.5	7	10	14.5
std./opt.	std.			opt.	

Chip conveyor Option



Chip conveyor type	Material	Description
Hinged belt	Steel	Most typical type of chip conveyor. Appropriate for steel materials generating chips of length of 30 mm or more.
Magnetic scrapper	Cast iron	Chip conveyor with magnet equipped: Appropriate for cast iron workpieces generating fine chips.

Coolant chiller Option

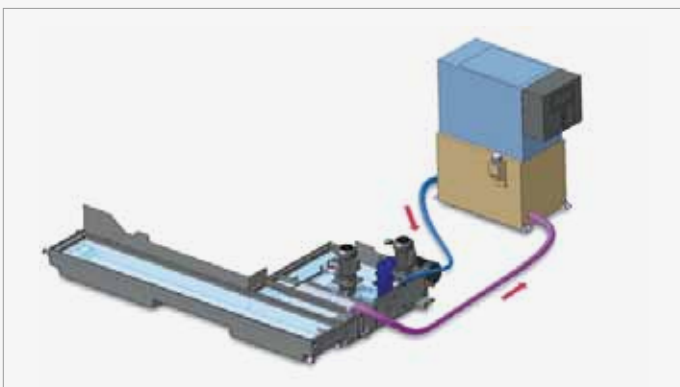

Detachable coolant chiller is recommended to keep thermal error minimal and get higher machining precision.

Part catcher Option



The part catcher automatically accepts parts completed of machining, and ejects them out of the system.



DOOSAN-FANUC i

Apply Fanuc CNC on the Doosan machine to fulfill best performance and productivity

User-friendly OP Panel

The operation panel of new design enhances operating convenience by common buttons and tpoisiioning, and uses qwerty type keyboard for easy and fast operation.

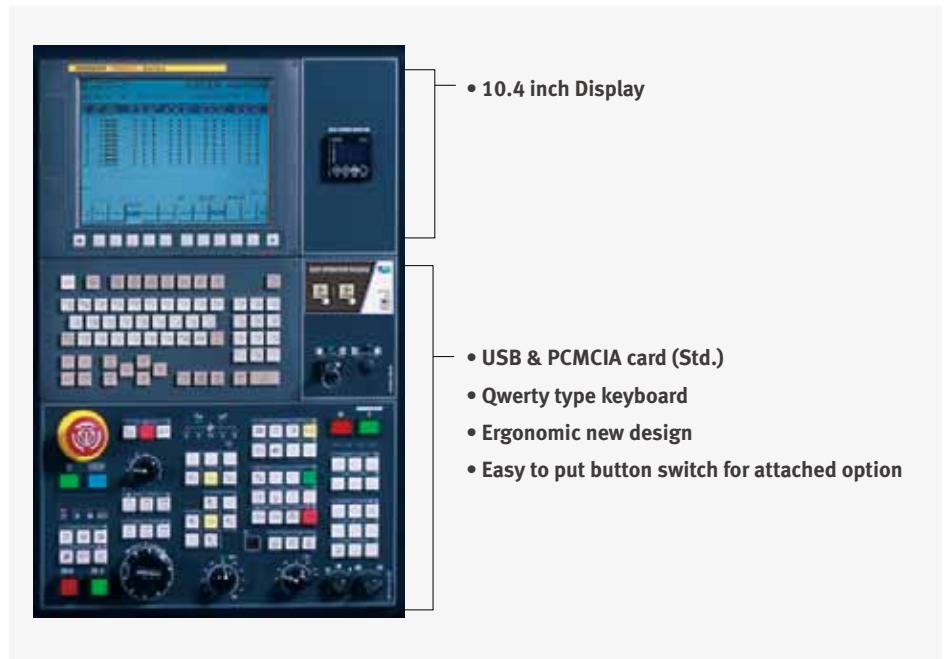

Easy Operation Package

Improve Productivity

Reduced non-cutting cycle time
10%

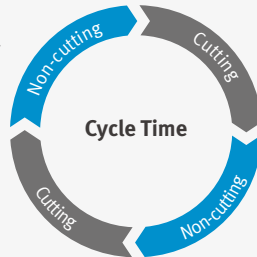

Non-cutting time during machining process is dramatically reduced to guarantee the highest productivity.

Work management



The function is capable of checking operation hours of the system, and quantity of finished workpieces.

Tool load monitoring option



During cutting operation, abnormal load caused by wear or damage of the tool is detected and an alarm is triggered to prevent further damage.

Tailstock thrust force setting option

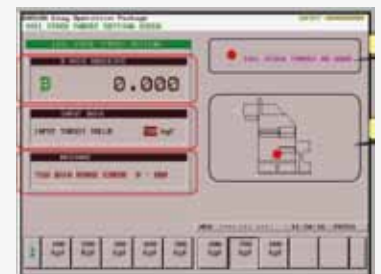

Thrust of the tailstock is easily set in an interactive menu screen.

Spindle Power – Torque Diagram

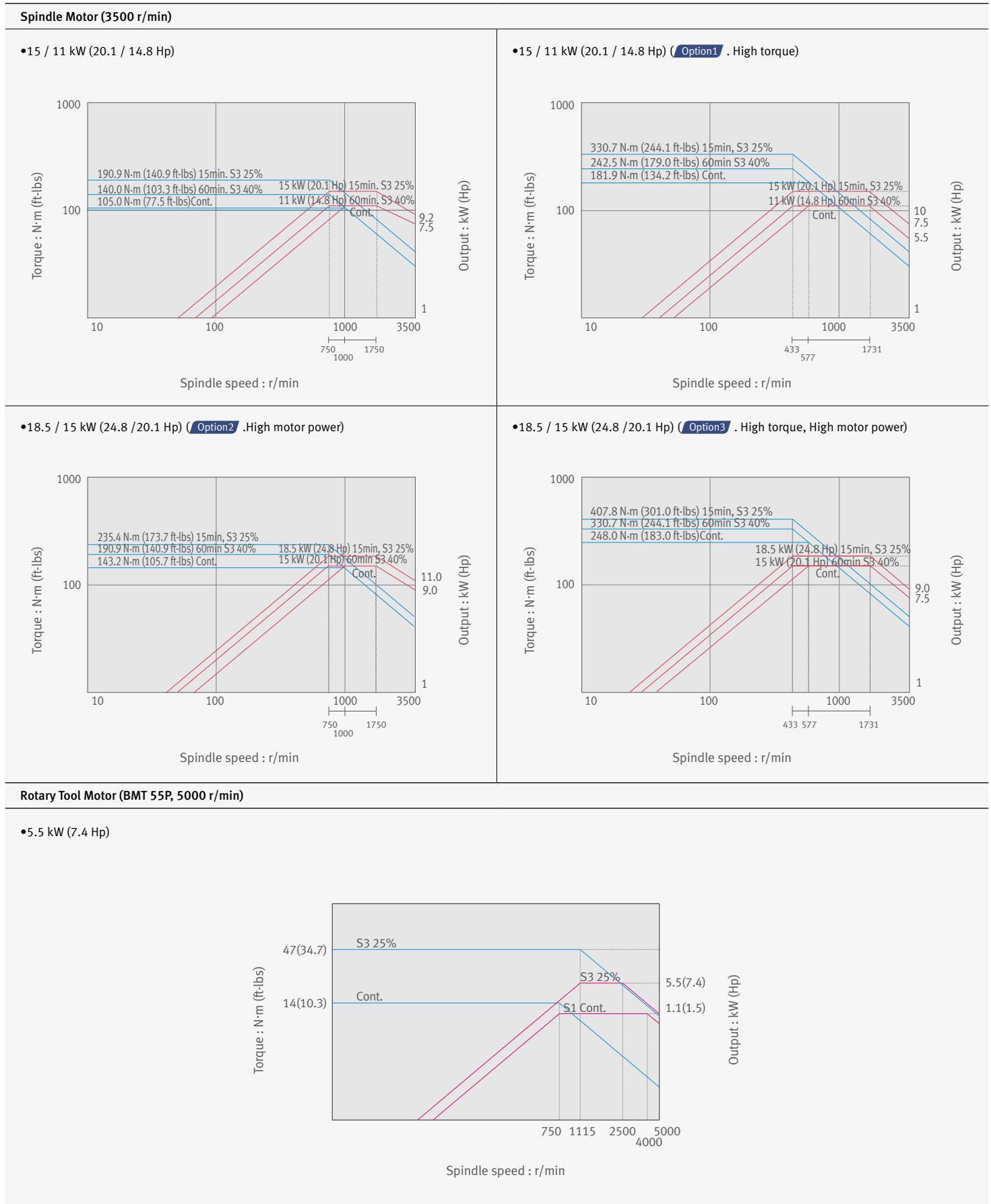

External Dimensions

Lynx 300 series

Unit: mm (inch)

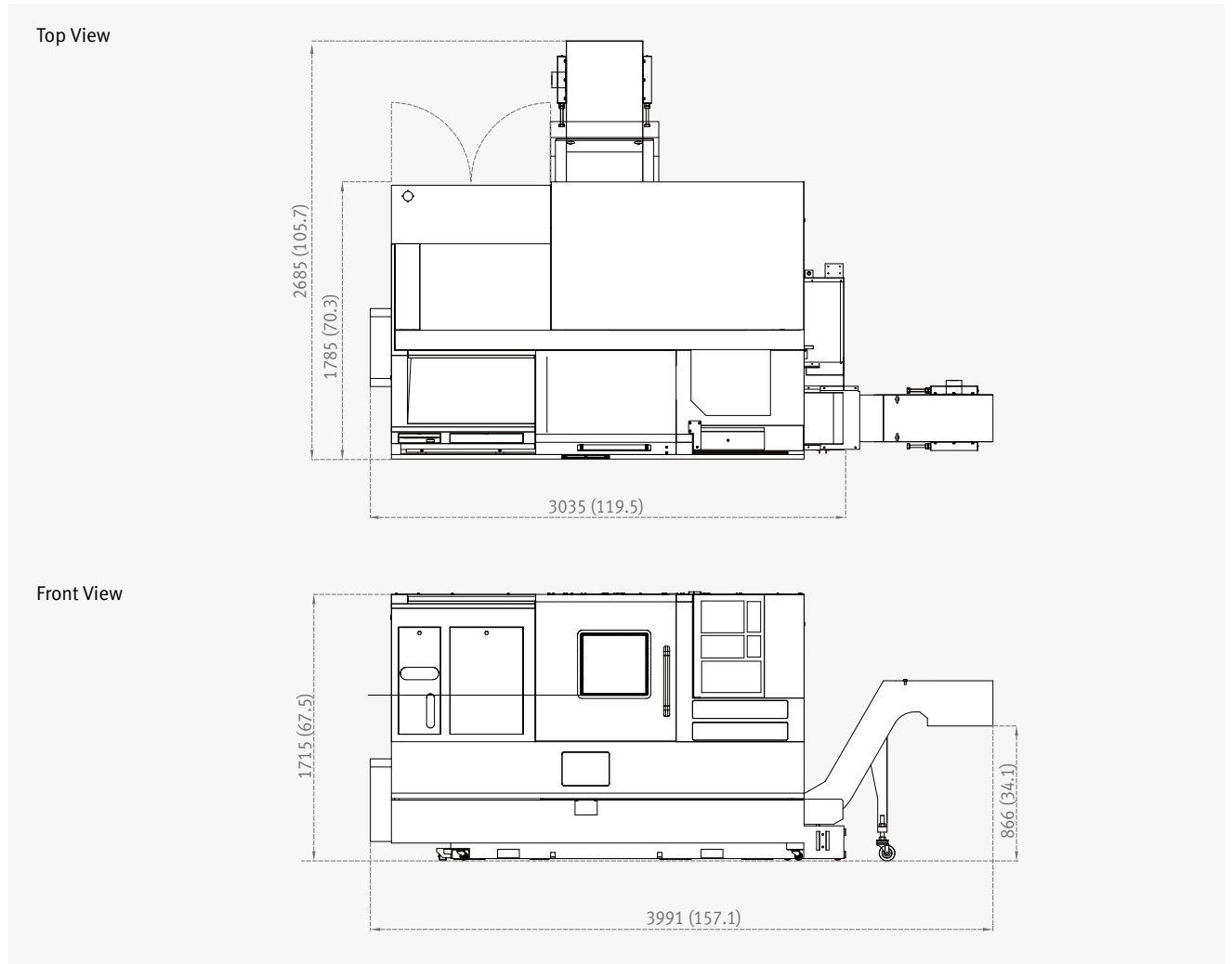

Tool Interference Diagram

Lynx 300

Unit: mm (inch)

Lynx 300M

Unit: mm (inch)

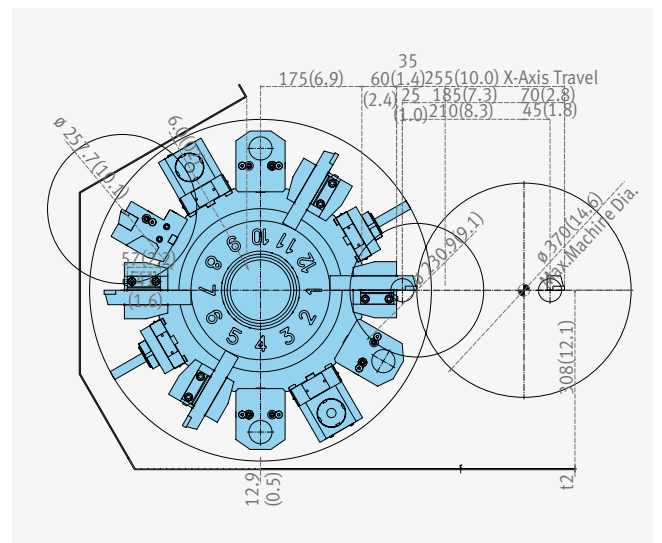
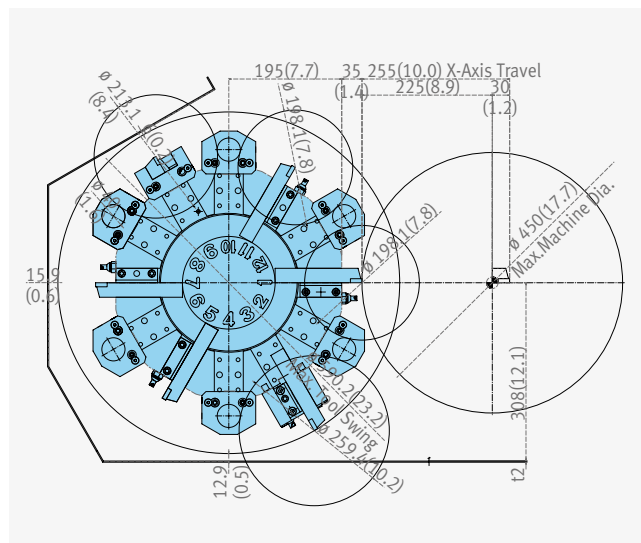

Tooling System

Lynx 300

Unit: mm (inch)

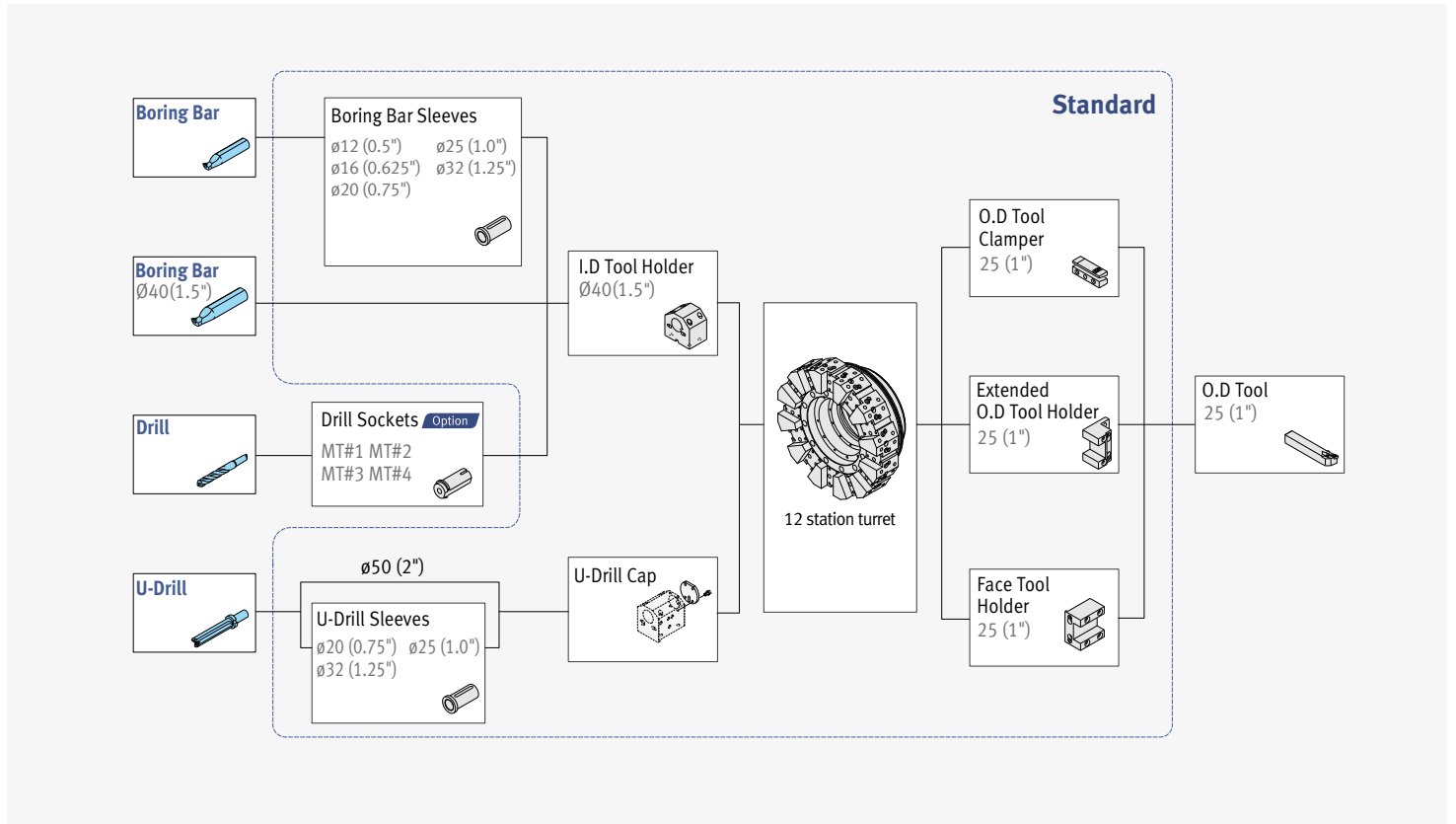

Lynx 300M

Unit: mm (inch)

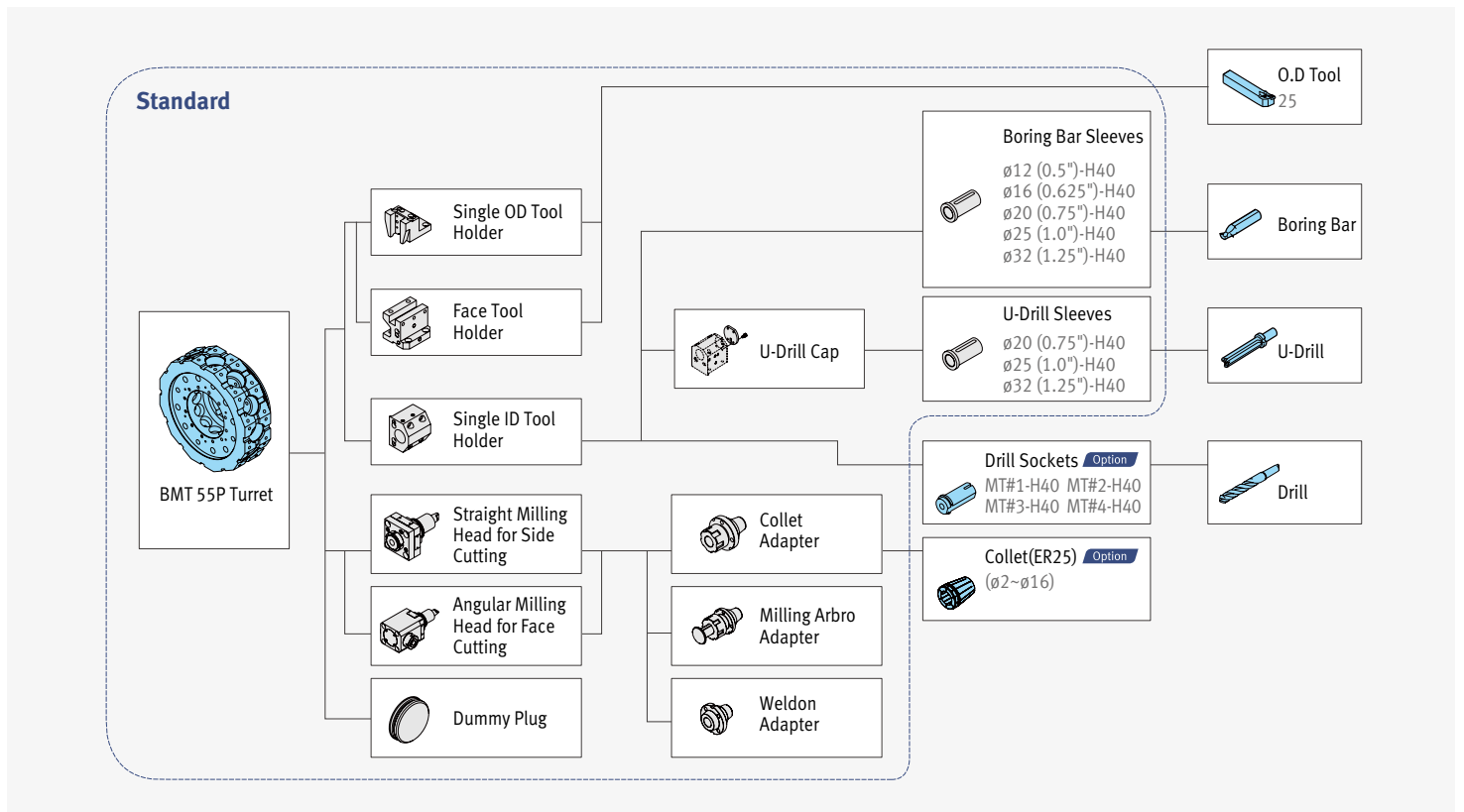

Working Range

Basic information

Structure
Main Components

Detailed Information

Standard/Option
Applications
Diagrams
Specifications

Customer Support

Lynx 300

Unit: mm (inch)

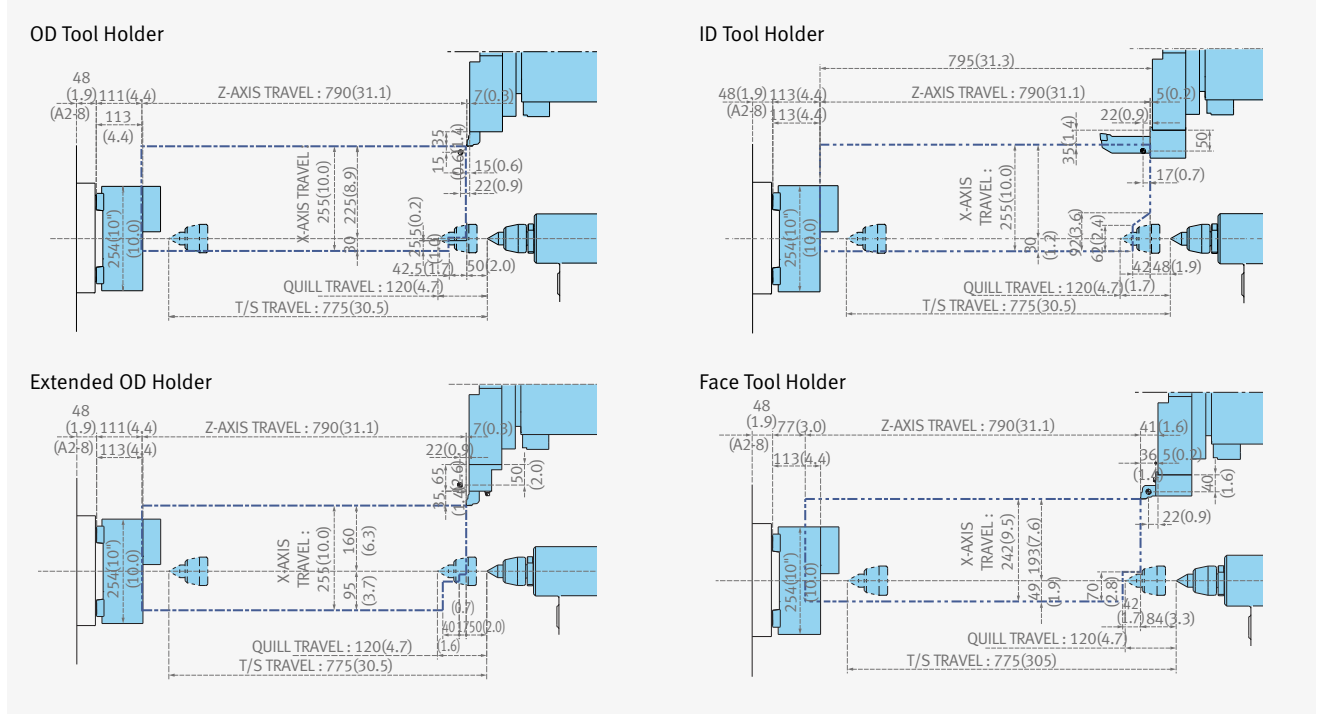

Lynx 300M

Unit: mm (inch)

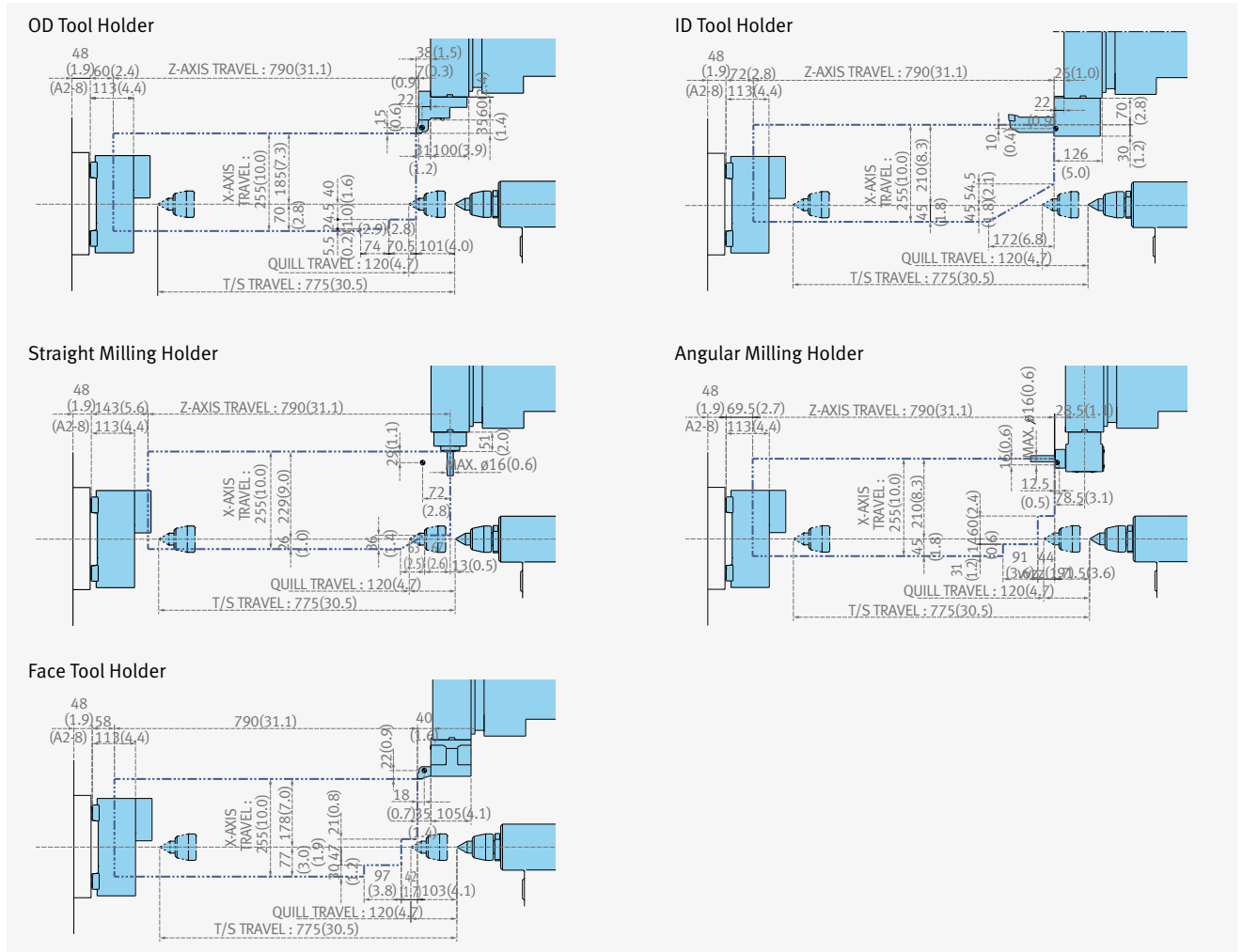

Machine Specifications



Description		Unit	Lynx 300	Lynx 300M	
Capacity	Swing over bed	mm (inch)	651 (25.6)		
	Swing over saddle	mm (inch)	461 (18.1)		
	Recom. Turning diameter	mm (inch)	254 (10.0)		
	Max. Turning diameter	mm (inch)	450 (17.7)	370 (14.6)	
	Max. Turning length	mm (inch)	765 (30.1)	712 (28.0)	
	Chuck size	inch	10		
	Bar working diameter	mm (inch)	76 (3.0)		
Travels	Travel distance	X-axis	255 (10.0)		
		Z-axis	790 (31.1)		
Feedrates	Rapid Traverse Rate	X-axis	24 (945)		
		Z-axis	30 (1181)		
Spindle	Max. Spindle speed	r/min	3500		
	Main spindle motor power	kW (Hp)	15 / 11 {18.5 / 15} <15min. / cont.> (20 / 15 {25 / 20})		
	Max. Spindle Torque for Turning	N-m (lbft)	191 {235.4 / 327.4 / 403.3} (141 {174 / 241 / 297})		
	Spindle nose	ASA	A2-8		
	Spindle bearing diameter (Front)	mm (inch)	120 (4.7)		
	Spindle through hole diameter	mm (inch)	86 (3.4)		
	Min. spindle Indexing angle(C-axis)	deg	-	0.001	
Turret	No. of tool stations	ea	12		
	OD tool size	mm (inch)	25 (1.0)		
	Max. boring bar size	mm (inch)	40 (1.6)		
	Turret Indexing time(1 station swivel)	s	0.15		
	Max. Rotary tool speed	r/min	-	5000	
	Rotary tool motor power	kW (Hp)	-	5.5 (7.5)	
Tailstock	Tailstock travel	mm (inch)	775 (30.5)		
	Quill diameter	mm (inch)	80 (3.1)		
	Quill travel	mm (inch)	120 (4.7)		
	Quill bore taper	MT	MT#4		
Power source	Electric power supply(rated capacity)	kVA	30.50	32.62	
Machine Dimensions	Length	mm (inch)	3035 (119.5)		
	Width	mm (inch)	1785 (70.3)		
	Height	mm (inch)	1715 (67.5)		
	Weight	kg (lb)	4000 (8800)	4050 (8910)	
CNC	NC system		DOOSAN-FANUC i		

* {} : Option

NC Unit Specifications

● Standard ○ Optional X N/A

Basic information

Structure
Main Components

Detailed Information

Standard/Option
Applications
Diagrams
Specifications

Customer Support

DOOSAN-FANUC i

		Specification	Lynx 300	Lynx 300M	
1	Controlled axis	Controlled axes	2(X,Z)	3(X,Z,C)	
2		Axis control by PMC	●	●	
3		Torque control	●	●	
4		Inch/metric conversion	●	●	
5		Stored limit check before move	●	●	
6		Unexpected disturbance torque detection function	●	●	
7		Position switch	●	●	
8	Operation	DNC operation with memory card	●	●	
9		Handle interruption	○	○	
10		Manual handle retrace	○	○	
11	Interpolation functions	Nano interpolation	●	●	
12		Linear interpolation	●	●	
13		Circular interpolation	●	●	
14		Helical interpolation	X	○	
15		Thread cutting, synchronous cutting	●	●	
16		Thread cutting retract	●	●	
17		Continuous threading	●	●	
18		High-speed skip	Input signal is 8 points.	○	○
19		2nd reference position return	G30	●	●
20	Feed function	AI contour control I	○	○	
21		AI contour control II	○	○	
22		Rapid traverse block overlap	●	●	
23	Program input	Optional block skip	9 pieces	●	●
24		Absolute/incremental programming	Combined use in the same block	●	●
25		Diameter/Radius programming		●	●
26		Automatic coordinate system setting		●	●
27		Workpiece coordinate system	G52 - G59	●	●
28		Chamfering/Corner R		●	●
29		Custom macro		●	●
30		Addition of custom macro common variables	#100 - #199, #500 - #999	●	●
31		Interruption type custom macro		●	●
32		Canned cycle		●	●
33		Multiple repetitive cycles	G70~G76	●	●
34		Multiple repetitive cycles II	Pocket profile	●	●
35		Canned cycle for drilling		●	●
36		Coordinate system shift		●	●
37	Direct input of coordinate system shift		●	●	
38	Pattern data input		●	●	
39	Operation Guidance Function	EZ Guide i	○*1)	○*1)	
40		EZ Operation package	●	●	
41	Auxiliary/ Spindle speed function	Constant surface speed control	●	●	
42		Rigid tap	●	●	
43		Arbitrary speed threading	○	○	
44		Tool offset pairs	64-pairs	●	●
45		Tool offset pairs	99-pairs	○	○
46		Tool radius/Tool nose radius compensation		●	●
47		Tool geometry/wear compensation		●	●
48		Automatic tool offset		●	●
49		Direct input of offset value measured B		●	●
50		Tool life management		●	●
51	Accuracy compensation function	Backlash compensation for each rapid traverse and cutting feed	●	●	
52		Stored pitch error compensation	○	○	
53	Editing operation	Part program storage size & Number of registerable programs	1280M(512KB)_400 programs	●	●
54		Part program storage size & Number of registerable programs	5120M(2MB)_400 programs	○	○
55		Playback		●	●
56	Data input/output	Fast data server	○	○	
57		External data input	●	●	
58		Memory card input/output	●	●	
59		USB memory input/output	●	●	
60		Automatic data backup	○	○	
61	Interface function	Embedded Ethernet	●	●	
62		Fast Ethernet	○	○	
63	Others	Display unit	8.4" color LCD	●	●
64		Display unit	10.4" color LCD	○	○
65	Robot interface	Robot interface with PMC I/O module	○	○	
66		Robot interface with PROFIBUS-DP	○	○	

*1) 10.4" display : standard / 8.4" display : option

Responding to Customers Anytime, Anywhere

Doosan Machine Tools' Global Network, Responding to Customer's Needs nearby, Anytime, Anywhere

Doosan machine tools provides a system-based professional support service before and after the machine tool sale by responding quickly and efficiently to customers' demands. By supplying spare parts, product training, field service and technical support, we can provide top class support to our customers around the world.

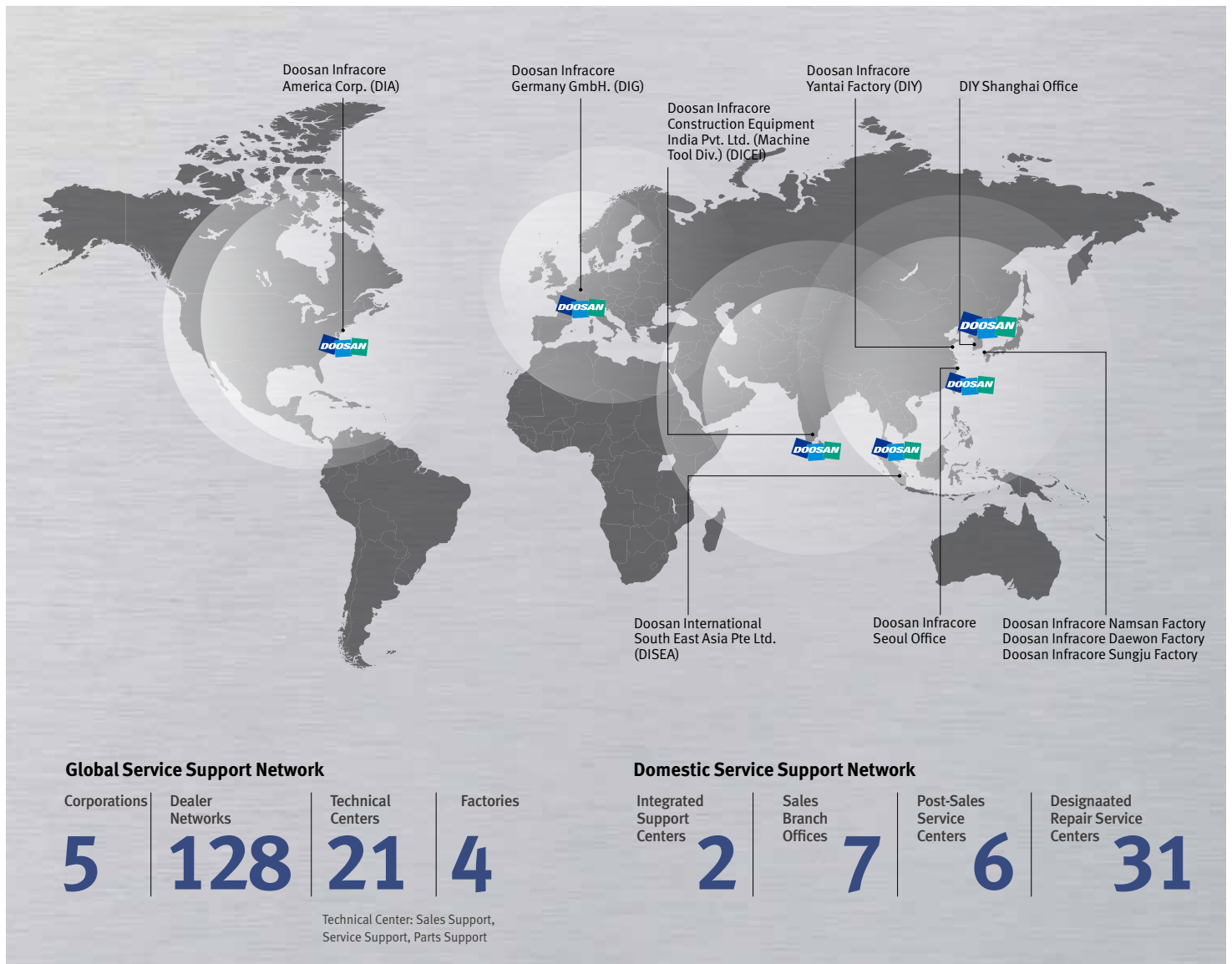

Customer Support Service

We help customers to achieve success by providing a variety of professional services from pre-sales consultancy to post-sales support.



Supplying Parts

- Supplying a wide range of original Doosan spare parts
- Parts repair service



Field Services

- On site service
- Machine installation and testing
- Scheduled preventive maintenance
- Machine repair



Technical Support

- Supports machining methods and technology
- Responds to technical queries
- Provides technical consultancy



Training

- Programming / machine setup and operation
- Electrical and mechanical maintenance
- Applications engineering

Lynx 300 series



Description	Unit	Lynx 300	Lynx 300M
Max. turning dia.	mm (inch)	450 (17.7)	370 (14.6)
Max. turning length	mm (inch)	765 (30.1)	712 (28.0)
Standard chuck size	inch	10	
Bar working dia.	mm (inch)	76 (3.0)	
Max. spindle speed	r/min	3500	
Max spindle power	kW (hp)	15(20)	
NC system		DOOSAN-FANUC i	



Doosan Machine Tools

<http://www.doosanmachinetools.com>

Optimal Solutions for the Future

Head Office

Doosan Tower 20th FL., 275, Jangchungdan-Ro
(St), Jung-Gu, Seoul
Tel +82-2-3398-8693 / 8671 / 8680
Fax +82-2-3398-8699

Doosan Infracore America Corp.

19A Chapin Rd., Pine Brook, NJ 07058, U.S.A.
Tel +1-973-618-2500
Fax +1-973-618-2501

Doosan Infracore Germany GmbH

Emdener Strasse 24, D-41540 Dormagen,
Germany
Tel +49-2133-5067-100
Fax +49-2133-5067-001

Doosan Infracore Yantai Co., LTD

13 Building, 140 Tianlin Road, Xuhui District,
Shanghai, China (200233)
Tel +86-21-6440-3384 (808, 805)
Fax +86-21-6440-3389

Doosan Infracore Construction Equipment India Pvt. Ltd. (Machine Tool Div.)

106 / 10-11-12, Amruthahalli, Byatarayanapura,
Bellary road, Bangalore-560 092, India
Tel +91-80-4266-0122 / 121 / 100

Doosan International South East Asia Pte Ltd.

42 Benoi Road, Jurong 629903, Singapore
Tel +65-6499-0200
Fax +65-6861-3459



* For more details, please contact Doosan.

* The specifications and information above-mentioned may be changed without prior notice.